

AC20 Variable Speed Drive

Advanced AC Drive for Motor Control in
General Purpose Applications
2 - 250 HP (1.5 - 180 kW)
Catalog HA540120



ENGINEERING YOUR SUCCESS.

⚠ Warning!

FAILURE OR IMPROPER SELECTION OR IMPROPER USE OF THE PRODUCTS AND/OR SYSTEMS DESCRIBED HEREIN OR RELATED ITEMS CAN CAUSE DEATH, PERSONAL INJURY AND PROPERTY DAMAGE.

- This document and other information from Parker Hannifin Corporation, its subsidiaries and authorized distributors provide product and/or system options for further investigation by users having technical expertise.
- The user, through its own analysis and testing, is solely responsible for making the final selection of the system and components and assuring that all performance, endurance, maintenance, safety and warning requirements of the application are met. The user must analyze all aspects of the application, follow applicable industry standards, and follow the information concerning the product in the current product catalog and in any other materials provided from Parker or its subsidiaries or authorized distributors.
- To the extent that Parker or its subsidiaries or authorized distributors provide component or system options based upon data or specifications provided by the user, the user is responsible for determining that such data and specifications are suitable and sufficient for all applications and reasonably foreseeable uses of the components or systems.

OFFER OF SALE

The items described in this document are hereby offered for sale by Parker Hannifin Corporation, its subsidiaries or its authorized distributors. This offer and its acceptance by the provisions stated in the detailed 'Offer of Sale' which is available upon request.

Overview.....	5
Technical Characteristics.....	8
Power Ratings	8
Electrical Characteristics.....	9
Environmental Characteristics	9
Standards and Conformance.....	9
Dimensions	10
Power Connections.....	11
Control Connections	12
Software.....	13
Parker Drive System Explorer (DSELite)	13
Accessories and Options.....	14
6901 Remote Mounting Keypad.....	14
Option Slots	14
General Purpose I/O (GPIO) Option Card.....	15
Encoder Feedback Card	15
Communication Option Cards	16
Braking Resistor	17
EMC Filter	17
Order Code.....	18

Parker Hannifin

The global leader in motion and control technologies and systems

Global Partnerships Global Support

Parker is committed to helping make our customers more productive and more profitable through our global offering of motion and control products and systems. In an increasingly competitive global economy, we seek to develop customer relationships as technology partnerships. Working closely with our customers, we can ensure the best selection of technologies to suit the needs of our customers' applications.



Electromechanical Technologies for High Dynamic Performance and Precision Motion

Parker electromechanical technologies form an important part of Parker's global motion and control offering. Electromechanical systems combine high performance speed and position control with the flexibility to adapt the systems to the rapidly changing needs of the industries we serve.



Electronic Motion and Controls Division Manufacturing

Parker drive products are manufactured globally to provide our customers with quality products at a competitive price point. In addition to factory-direct support, Parker provides sales assistance and local technical support through a group of dedicated sales teams and a network of authorized systems integrators, field service engineers, and technical distributors across the globe. For contact information, please refer to the Sales Offices listed on the back cover of this document or visit www.parker.com/emc



Rohnert Park, CA

Variable Speed Drive - AC20 Series

Overview

Description

The AC20 Advanced Compact Drive is a highly featured yet economical solution to general purpose motor control applications. AC20 provides speed or torque control in the power range of 2 - 250HP. Its compact dimensions house many features normally only associated with system drives, including sensorless vector mode for control of Permanent Magnet (PMAC) and AC induction motors, encoder feedback and I/O expansion option cards, Safe Torque Off and an onboard Ethernet port that supports major industrial Ethernet protocols. AC20 provides the perfect solution for OEM machine builders looking for a compact, cost-effective drive without compromising on performance.

Features

Simplicity

AC20 is designed to reduce the time and effort required to select, install, set up and commission. Two variants of option card are available, both user installable/retrofitable. Minimal wiring requirements with two easily accessed terminal rails and removable power cable brackets make AC20 fast and simple to install. All AC20s come with a high quantity of user configurable I/O and a user disconnectable C3 EMC filter as standard. Programming and commissioning is made simple through its easy to use integrated keypad and the DSELite programming tool.

Reliability

Proven technology and manufacturing techniques ensure AC20 has been engineered and built to deliver consistently outstanding levels of performance day in, day out - ensuring maximum uptime and productivity. With its standard conformally coated PCBs, AC20 is built to withstand C3 environments.

Compatibility

AC20 has been designed with system compatibility in mind. The compact footprint allows installation into existing spaces, while the I/O count has been chosen to allow maximum possible flexibility. The internal block diagram is fully featured to enable replacement of legacy Parker inverters, and the onboard Ethernet communications protocols aid integration into wider systems. Retrofittable, plug-in communications cards cover all popular protocols and are simple to configure.



Technical Characteristics - Overview

Power Supply	220-240 VAC \pm 10% Single Phase 220-240 VAC \pm 10% Three Phase 380-480 VAC \pm 10% Three Phase
Input Frequency	50/60 Hz \pm 10%
Power Range	2-250 HP (1.5 - 180 kW) HD
Overload	150% for 60 sec.
Output Frequency	0.5 - 590 Hz
Safe Torque Off (STO)	SIL2, PLd
Operating Temperature	0-40 °C (derate possible up to 45°C)*
Altitude	0-1000m (derate 1% per 100m up to 2000m max.)*

* Without communications option installed

Extra power when it's needed!

- 150% overload for 60 seconds to provide extra starting torque for high inertia loads

Features

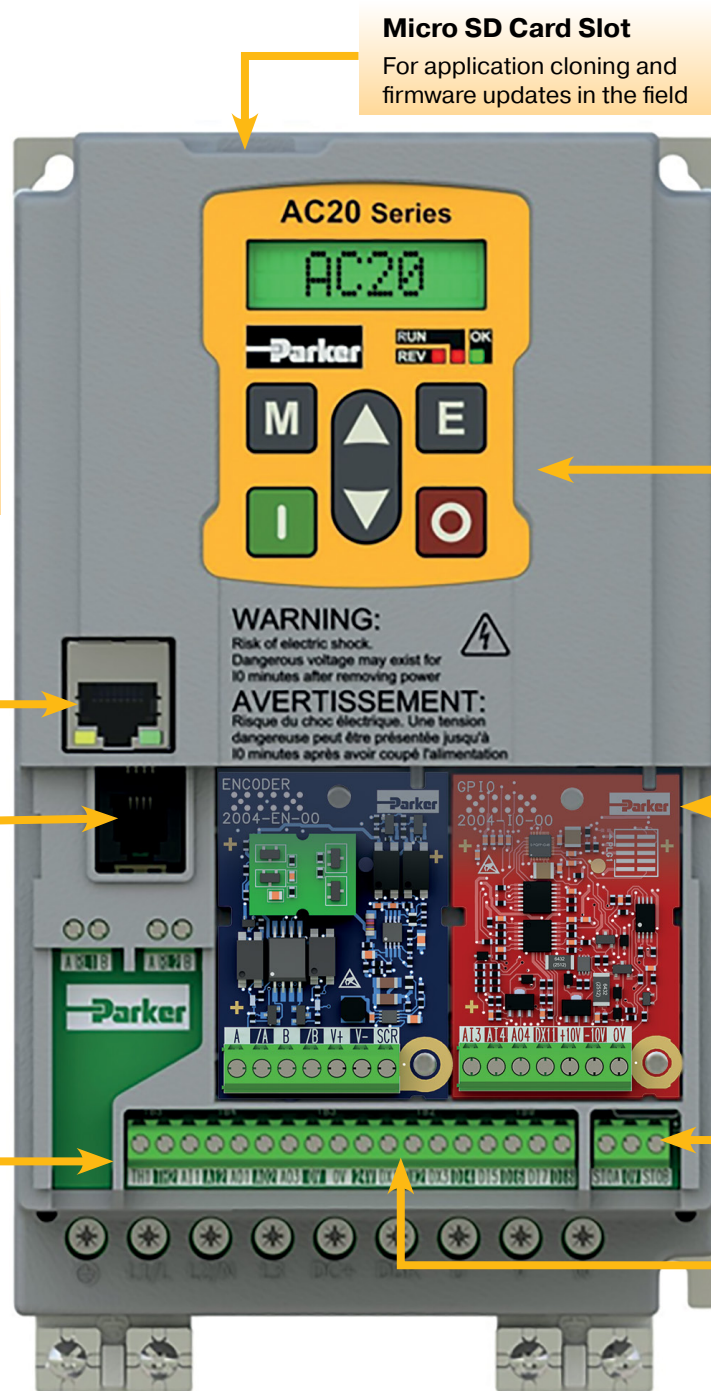

Micro SD Card Slot

For application cloning and firmware updates in the field

Built-in Display Keypad

Operate the drive and see real time diagnostic feedback through the backlit built-in display

Standard Ethernet Port

Ethernet/IP, Modbus TCP/IP, and ProfinetIO as standard. Access the drive webpage or program the drive through the popular and intuitive DSElite configuration tool

User-Installable Option Cards

- Encoder feedback card
- General Purpose I/O card

Use either or both in any combination, up to two cards per drive.

RJ11 Port for Remote Keypad

Connect an optional remote 6901 keypad to this standard port

Built-in Safe Torque Off

Independently certified STO to SIL2, PLd as standard. Complies with:

- EN ISO13849-1:2015
- EN 61800-5-2:2017
- EN 61508

Dedicated Motor Thermistor Input

PTC Motor Thermistor feedback connection as standard

User I/O

Extensive analog and digital I/O for maximum application flexibility

Power Cable Shielding Bracket (not shown)

- Frames 2-5 include a cable shielding and support bracket as standard

Standards & Compliance

The product is certified to the latest international standards:

Europe:

- Low Voltage Directive 2014/30/EC
- Electro-Magnetic Compatibility Directive 2006/42/EC
- EN61800-5-1:2007 + A11;2021
- EN61800-3:2018
- IE 2 Compliant

North America & Canada:

- UL 61800-5-1
- CSA22.2 #274.17

Applications

AC20 provides a straight-forward approach to general purpose industrial motor control applications across a wide range of industries, giving users the benefits of the inherent energy-saving properties of using a variable speed drive, as well as the improved reliability and extended service life benefits associated with smoother starting and stopping of regularly cycling loads.

Typical applications for AC20 include...

- **Conveyor**
- **Centrifuge**
- **Fans**
- **Mixers**
- **Packaging Machines**
- **Textile Machines**
- **Strapping Machines**
- **Labelling Machines**
- **Industrial Washing Machines**
- **Machine Tool Spindles**
- **Roller Doors**



Conveyors

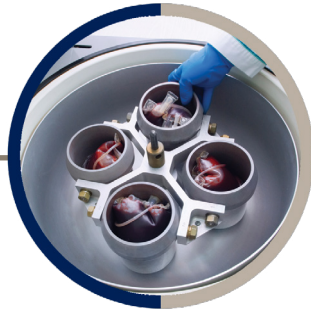

Centrifuges



Fans



Mixers

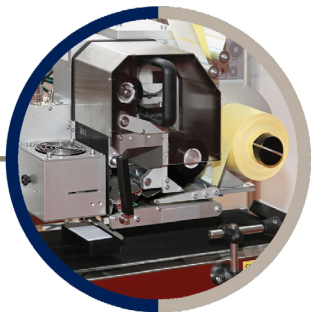

Packaging Machines

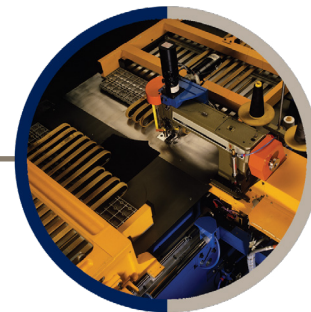

Textile Machines

Technical Characteristics

Power Ratings

230 VAC, Single Phase Supply Voltage				
HD Power Rating [HP]*	Order Code	Input Current [A]	Output Current [A]	Frame Size
2	20G-12-0070-BF	14	7	2
3	20G-12-0100-BF	18	10	

230 VAC, Three Phase Supply Voltage				
HD Power Rating [HP]*	Order Code	Input Current [A]	Output Current [A]	Frame Size
2	20G-32-0070-BF	6.8	7	2
3	20G-32-0100-BF	10	10	
5	20G-33-0170-BF	17	17	3
7.5	20G-34-0210-BF	22	21	4
10	20G-35-0300-BF	28	30	5
15	20G-35-0400-BF	39	40	

460 VAC, Three Phase Supply Voltage				
HD Power Rating [HP]*	Order Code	Input Current [A]	Output Current [A]	Frame Size
2	20G-42-0040-BF	3.8	3.5	2
3	20G-42-0065-BF	5.2	5.7	
5	20G-42-0090-BF	8	7.8	
7.5	20G-43-0120-BF	11	10	3
10	20G-43-0170-BF	13.3	15	
15	20G-44-0230-BF	19	20	4
20	20G-44-0320-BF	24.6	28	
25	20G-45-0380-BF	30	33	5
30	20G-45-0440-BF	35	38	
40	20G-45-0600-BF	46	52	
50	20G-46-0750-BF	58	65	6
60	20G-46-0900-BF	69	78	
75	20G-47-1100-BF	87	96	7
100	20G-47-1500-BF	115	130	
125	20G-48-1800-BF	144	157	8
150	20G-48-2200-BF	173	191	
200	20G-48-2650-BF	231	230	
250	20G-410-3600-BF	288	313	10

*HD = Heavy Duty. Provides 150% overload current for 60 seconds.

Technical Characteristics

Electrical Characteristics

Power Supply	220 - 240 VAC ±10 % Single Phase 220 - 240 VAC ±10 % Three Phase 380 - 480 VAC ±10 % Three Phase
Input Frequency	50/60 Hz ±10 %
Overload	150% for 60 sec.
Output Frequency	0.5 - 590 Hz
Max. Switching Frequency	10 kHz
Control Modes	Volts/Hertz, Sensorless Vector (SV) or Closed-Loop Vector Mode (Induction only)
Supported Motors	Induction & PMAC

Environmental Characteristics

Temperature range	0-40 °C (derate possible up to 45 °C)*
Humidity	Up to 90 % Relative Humidity, non-condensing
Vibration	< 0.5 g
Altitude	0-1000 m (derate 1% per 100m up to max. 2000m)
Protection Degree	IP20
Pollution Degree	Category 2
Chemically Active Substances	Compliance with EN60271-3-3: C3

* De-rating only possible without communications option fitted

Standards and Compliance

Europe	This product conforms with: - Low Voltage Directive 2014/30/EU - Electro-Magnetic Compatability Directive 2006/42/EC - EN61800-5-1:2007+A11:2021 - EN61800-3:2018
North America / Canada	Certified to the following standards: - UL61800-5-1 - CSA22.2#274-17 as an open-type drive
STO	Independently certified to: - EN ISO13849-1:2015 - EN 61800-5-2:2017 - EN 61508
RoHS	This product complies with the RoHS substance restrictions in accordance with EC Directive 2011/65/EU
REACH	This product complies with the REACH regulations EC1907/2006

Dimensions

Frame	Height (H) [in/mm]	Height (H1) [in/mm]	Height (H2) [in/mm]	Width (W) [in/mm]	Depth (D) [in/mm]	Weight [lb/kg]
2	7.09/180.0	7.60/193.0	8.96/227.5	4.27/108.4	7.28/185.0	4.4/2.0
3	9.35/237.5	9.76/248.0	11.10/281.9	5.57/141.6	7.24/184.0	7.3/3.3
4	10.43/265.0	11.14/283.0	12.65/321.4	6.34/161.0	7.72/196.0	9.7/4.4
5	13.39/340.0	14.09/358.0	15.80/401.4	8.27/210.0	8.67/220.2	17.7/8.0
6	17.13/435.0	18.31/465.0	n/a	10.32/262.0	9.47/240.5	30.9/14.0
7	24.80/630.0	24.55/623.5	n/a	13.98/355.0	10.43/265.0	92.6/42.0
8	30.12/765.0	29.72/755.0	n/a	15.98/406.0	11.81/300.0	124.6/56.5
9	30.12/765.0	30.63/778.0	n/a	20.08/510.0	12.83/326.0	191.8/87.0
10	35.83/910.0	36.42/925.0	n/a	21.65/550.0	13.44/341.5	271.2/123.0

Frame 2-5

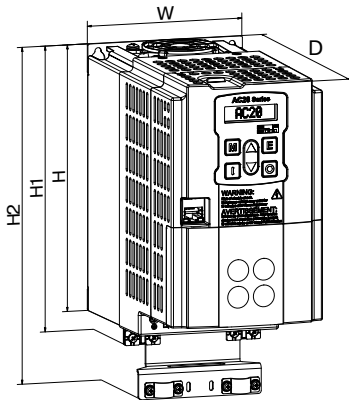

Frame 6

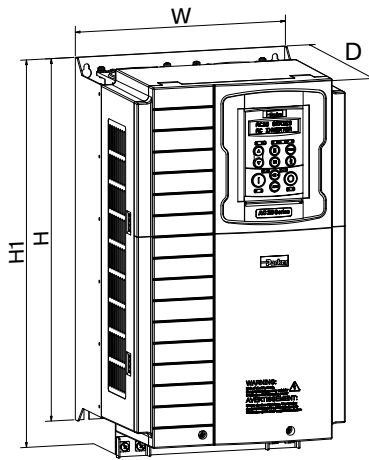

Frame 7-10

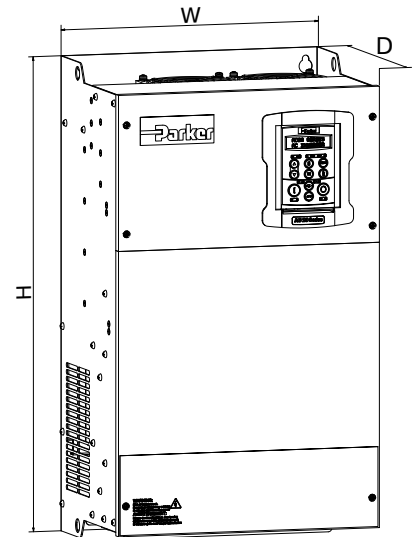

Power Connections

Frame 2-4

Terminal	Description
PE	Earth/Ground
L1 / L	Supply Input phase L1 / Live
L2 / N	Supply Input phase L2 / Neutral
L3	Supply Input phase L3
DC+	DC+ Dynamic Brake Resistor connection (+)
DBR	Dynamic Brake Resistor connection (-)
U	Motor Output phase U
V	Motor Output phase V
W	Motor Output phase W

Frame 5-6

Terminal	Description
PE	Earth/Ground
L1	Supply Input phase L1
L2	Supply Input phase L2
L3	Supply Input phase L3
DC+	DC+ Dynamic Brake Resistor connection (+)
DC-	DC-
DBR	Dynamic Brake Resistor connection (-)
U	Motor Output phase U
V	Motor Output phase V
W	Motor Output phase W

Frame 7-10

Terminal	Description
PE	Earth/Ground
DC+	DC+ Dynamic Brake Resistor connection (+)
DC-	DC-
DBR	Dynamic Brake Resistor connection (-)
L1	Supply Input phase L1
L2	Supply Input phase L2
L3	Supply Input phase L3
U	Motor Output phase U
V	Motor Output phase V
W	Motor Output phase W



Control Connections

Label	Description
RLY1A	Relay Output 1 (Contact A)
RLY1B	Relay Output 1 (Contact B)
RLY2A	Relay Output 2 (Contact A)
RLY2B	Relay Output 2 (Contact B)
TH1	Motor Thermistor Input
TH2	Motor Thermistor Input
AIN1	Analog Input 1 ($\pm 10V$, 0-10V, 0-20mA, 4-20mA)
AIN2	Analog Input 2 ($\pm 10V$, 0-10V, 0-20mA, 4-20mA)
AOUT1	Analog Output 1 (0-10V, 0-20mA)
AOUT2	Analog Output 2 (0-10V, 0-20mA)
AOUT3	Analog Output 3 ($\pm 10V$, 0-10V)
0V	0V Reference for analog & digital I/O
0V	0V Reference for analog & digital I/O
24V	24V user supply
DIO1	Digital Input / Output 1 (24V configurable)
DIO2	Digital Input / Output 2 (24V configurable)
DIN3	Digital Input / Output 3 (24V configurable)
DIN4	Digital Input 4
DIN5	Digital Input 5
DIN6	Digital Input 6
DIN7	Digital Input 7
DIN8	Digital Input 8
DIN9	Digital Input 9*
DIN10	Digital Input 10*
STO1	STO input channel A
STO0V	STO 0V reference
STO2	STO input channel B

* = Frames 6-10 only



Software

Parker Drive System Explorer (DSE Lite)

Parker drive configuration software Drive System Explorer (DSE) Lite is an easy to use drive configuration software package, designed to make programming your application as simple as possible without compromising on functionality.

DSE Lite is based around a straightforward block programming and an intuitive user interface which supports user-defined configurations and offers real-time monitoring and charting. DSE Lite allows the user to create, parameterize and configure user defined applications as well as parameterize and connect fixed Motor Control blocks with 70 user functions and up to 200 'links'

Thanks to the on-line help and pre-configured macro templates, users can achieve the optimum drive configuration without the need to navigate through complicated parameter menus.

DSE Lite for AC20 uses a standard Ethernet connection between PC and inverter, so no special cable is required.

DSE Lite is available free of charge to download here: discover.parker.com/DSELite_software

Features new to the AC20 include:

- Ethernet connectivity
- Network scan feature
- Drive LED identification
- Firmware installs over Ethernet
- Ability to save a project to on-board Flash memory
- Power 'on the bench' for programming

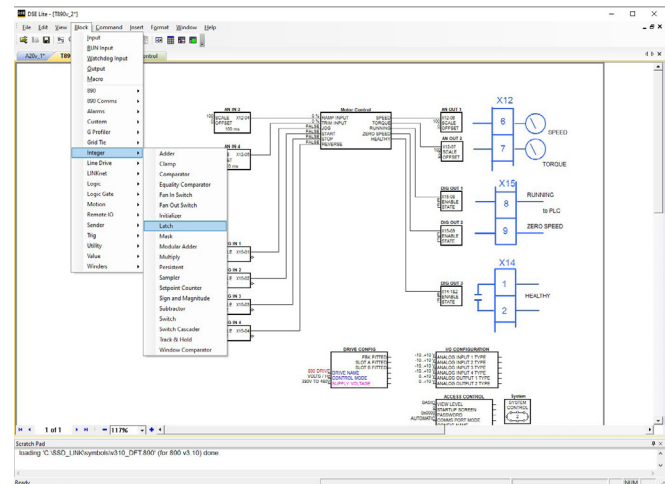
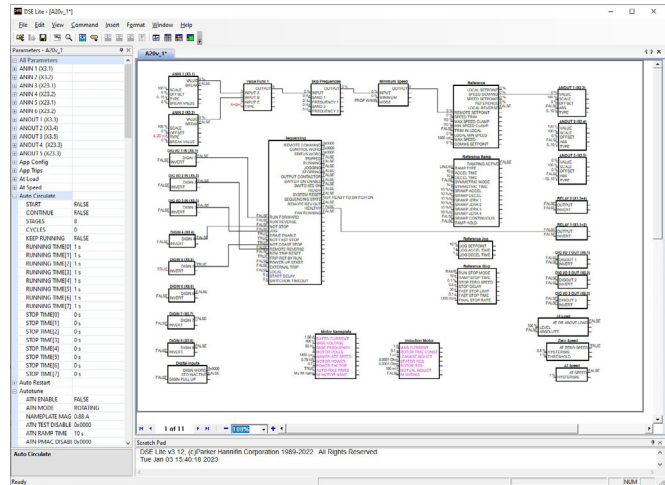

Accessories and Options

6901 Remote Mounting Keypad

The popular 6901 remote mounting keypad can be mounted away from the drive, such as on the door of an electrical enclosure. This interface allows users to configure, operate and monitor the drive without having to access the drive directly.

The remote keypad provides an alternative to the drive mounted keypad, offering a clear English language display and greater functionality. The remote mounting kit provides a mounting bezel and a 1.5 m cable that is plugged into the RJ11 port on the drive.



Order Code	Description
6901-00-G	6901 DisplayKeypad
6052-00-G	6901 remote mounting kit

Option Slots

The AC20 features three option slots. All options are user installable and are ordered separately. Two option slots will accept either a speed feedback option or general-purpose IO expansion module, with a third option slot dedicated to communications option modules.



Accessories and Options

General Purpose I/O (GPIO) Option Card

Description:

The general purpose I/O (GPIO) option module offers users the opportunity to expand the drive's standard I/O capability, allowing more complex motor control solutions to be implemented. The option can be installed in either slot 1 or 2, and two options can be fitted at the same time to maximize the I/O count. For example, two I/O options will give an additional 4 analog inputs



2004-IO-00	GPIO Option
Analog inputs	2x Analog inputs ($\pm 10V$, 0-10V)
Analog output	1x Analog outputs ($\pm 10V$, 0-10V)
Digital I/O	Digital Input/Output 1 (24V configurable)
Reference voltages	+/- 10V References

Terminal	Label		Description
	Slot 1	Slot 2	
AI3	AIN3	AIN5	Analog input 3/5 ($\pm 10V$, 0-10V)
AI4	AIN4	AIN6	Analog input 4/6 ($\pm 10V$, 0-10V)
AO4	AOUT4	AOUT5	Analog output 4/5 ($\pm 10V$, 0-10V)
DX11	DIO11	DIO12	Digital I/O 11/12 (24V configurable)
+10V	+10V	+10V	+ 10V Reference voltage
-10V	-10V	-10V	- 10V Reference voltage
0V	0V	0V	0V Reference for analog & digital I/O

Encoder Feedback Card

Description:

The HTTL pulse encoder feedback module allows an incremental encoder to be connected to the AC20, allowing users to take full advantage of closed-loop vector control. The option can be fitted in either slot 1 or 2, and two identical options can be fitted at the same time, allowing for simple speed following applications.

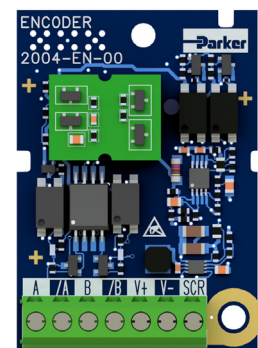

2004-EN-00	Encoder Feedback Option
Maximum input frequency	250 kHz per channel
Input format	Quadrature
Output supply voltage	5V, 12V, 15V, 20V

Terminal	Label		Description
	Encoder 1	Encoder 2	
A	A	A	Channel A input
/A	/A	/A	Channel /A input
B	B	B	Channel B input
/B	/B	/B	Channel /B input
V+	V+	V+	Encoder supply +
V-	V-	V-	Encoder supply -
SCR	SCR	SCR	Cable screen/shield

Accessories and Options

Communication Option Cards

The AC20 takes advantage of commonly available third-party communication modules, allowing communication over a range of popular protocols. Also included in the supported range are Ethernet IP and ProfiNet modules, for when two ports are required. Adding an Ethernet based option card is possible in addition to the onboard Modbus TCP/IP, ProfiNet or Ethernet IP port.

2003-CB-00	CANopen communication interface
Supported Protocols	DS301 V4.02
Communication Speed	10 k, 20 k, 50 k, 125 k, 250 k, 500 k, 1 Mbits/s or automatically detected
Max. number of devices	127
Supported Messages	SDO, PDO, NMT, SYNC



2003-EC-00	EtherCAT communication interface
Supported Protocols	CANopen over EtherCAT (CoE) DS301 compliant
Communication Speed	100 Mbits/s
Max. number of devices	65534
Supported Messages	SDO, PDO, NMT, SYNC



2003-IP-00	Ethernet IP communication interface
Supported Protocols	Ethernet IP
Communication Speed	10/100 Mbits/s full/half duplex
Max. number of devices	Virtually unlimited
Supported Messages	Up to 256 bytes of consumed data and 256 bytes of produced data, CIP parameter object support, explicit messaging



2003-PB-00	PROFIBUS DP-V1 communication interface
Supported Protocols	PROFIBUS-DP; Demand data and Data exchange
Communication Speed	Up to 12 Mbits/s; automatically detected
Max. number of devices	32 per segment, 126 total
Supported Messages	Up to 152 bytes cyclic I/O, 68 bytes class 1 and 2 acyclic data, 152 bytes configuration data. GSD file provided



2003-RS-00	RS485 / Modbus RTU communication interface
Supported Protocols	Modbus RTU
Communication Speed	1200 to 115,200 bits/s
Max. number of devices	247
Supported Messages	Up to 256 bytes of cyclic I/O data in each direction



2003-PN-00	PROFINET I/O communication interface
Supported Protocols	PROFINET I/O generic device
Communication Speed	10/100 Mbits/s full/half duplex
Max. number of devices	Up to 128 submodules in total
Supported Messages	Up to 256 bytes of cyclic I/O in data in each direction



Accessories and Options

Line Protection

Line fuses and reactors offer drive protection from short circuits and supply transients. When used with the fuses mentioned here, a short circuit rating of 50,000 amps can be achieved.

230 V, Single Phase Supply Voltage				
AC20 [HP]*	Frame Size	Catalog Number	Line Fuses part number	Line Reactor part number
2	2	20G-12-0070-BF	CS470407U025	CO540100U019
3		20G-12-0100-BF	CS470407U025	CO540100U019

230 V, Three Phase Supply Voltage				
AC20 [HP]*	Frame Size	Catalog Number	Line Fuses part number	Line Reactor part number
2	2	20G-32-0070-BF	CS470407U010	CO540100U010
3		20G-32-0100-BF	CS470407U020	CO540100U012
5	3	20G-33-0170-BF	CS470407U025	CO540100U019
7.5	4	20G-34-0210-BF	CS470407U030	CO540100U025
10	5	20G-35-0300-BF	CS470408U050	CO540100U034
15		20G-35-0400-BF	CS470408U050	CO540100U048

460 V, Three Phase Supply Voltage				
AC20 [HP]*	Frame Size	Catalog Number	Line Fuses part number	Line Reactor part number
2	2	20G-42-0040-BF	CS470407U005	CO540101U004
3		20G-42-0065-BF	CS470407U010	CO540101U005
5		20G-42-0090-BF	CS470407U020	CO540101U008
7.5	3	20G-43-0120-BF	CS470407U020	CO540101U011
10		20G-43-0170-BF	CS470407U030	CO540101U014
15	4	20G-44-0230-BF	CS470407U030	CO540101U030
20		20G-44-0320-BF	CS470407U040	CO540101U030
25	5	20G-45-0380-BF	CS470408U050	CO540101U030
30		20G-45-0440-BF	CS470408U050	CO540101U045
40		20G-45-0600-BF	CS470408U080	CO540101U055
50	6	20G-46-0750-BF	CS470408U100	CO540101U065
60		20G-46-0900-BF	CS470408U125	CO540101U077
75	7	20G-47-1100-BF	CS350263	CO540101U110
100		20G-47-1500-BF	CS470408U200	CO540101U150
125	8	20G-48-1800-BF	CS470408U250	CO540101U150
150		20G-48-2200-BF	CS350265	CO540101U185
200		20G-48-2650-BF	CS470408U400	CO540101U240
250	10	20G-410-3600-BF	CS470408U450	CO540101U340

Line fuses are mandatory on all sizes

Line reactors are mandatory on frames 1-6 and recommended on frames 7-10

Accessories and Options

Braking Resistor

During deceleration, or with an over-hauling load, the motor acts as a generator. Energy flows back from the motor into the DC link capacitors within the drive, causing their voltage to rise. If this voltage exceeds a maximum value, the drive will trip to protect the capacitors and internal power devices. The amount of energy that can be absorbed by the capacitors can vary between different applications causing the drive to trip on overvolts. To increase the drive's dynamic braking capability, high power resistor(s), connected across the DC link, allow the dissipation of this excess energy for short term stoppage or braking.

230 V, Single Phase Supply Voltage						
AC20 [HP]*	Frame Size	Catalog Number	Braking Kit	Min ohms	Braking Kit ohms	Braking kit Watts
2	2	20G-12-0070-BF	LA471356	80	100	100
3		20G-12-0100-BF	LA471356	80	100	100

230 V, Three Phase Supply Voltage						
AC20 [HP]*	Frame Size	Catalog Number	Braking Kit	Min ohms	Braking Kit ohms	Braking kit Watts
2	2	20G-32-0070-BF	LA471356	80	100	100
3		20G-32-0100-BF	LA471356	80	100	100
5	3	20G-33-0170-BF	LA471359	30	56	500
7.5	4	20G-34-0210-BF	LA471359	30	56	500
10	5	20G-35-0300-BF	LA471362	15	25	756
15		20G-35-0400-BF	LA471362	15	25	756

460 V, Three Phase Supply Voltage						
AC20 [HP]*	Frame Size	Catalog Number	Braking Kit	Min ohms	Braking Kit ohms	Braking kit Watts
2	2	20G-42-0040-BF	LA471355	95	200	100
3		20G-42-0065-BF	LA471357	90	100	200
5		20G-42-0090-BF	LA471357	90	100	200
7.5	3	20G-43-0120-BF	LA471357	90	100	200
10		20G-43-0170-BF	LA471357	90	100	200
15	4	20G-44-0230-BF	LA471359	50	56	500
20		20G-44-0320-BF	LA471361	30	30	750
25	5	20G-45-0380-BF	LA471361	30	30	750
30		20G-45-0440-BF	LA471361	30	30	750
40		20G-45-0600-BF	LA471362	25	25	756
50	6	20G-46-0750-BF	LA471365	14	15	1135
60		20G-46-0900-BF	LA471365	14	15	1135
75	7	20G-47-1100-BF	LA471365	14	15	1135
100		20G-47-1500-BF	LA471367	11	8	1502
125	8	20G-48-1800-BF	LA471367	7	8	1502
150		20G-48-2200-BF	LA471367	7	8	1502
200		20G-48-2650-BF	LA471370	4	3	4563
250	10	20G-410-3600-BF	LA471370	3	3	4563

All braking kits include a thermal overload with auxiliary contact.

All braking kits are rated for occasional stopping duty, not more than 6 stops per hour.

For continuous power absorption or intermittent duty braking, consult factory.

EMC Filter

The AC20 is supplied as standard with an EMC filter fitted that meets the requirements of a class C3 environment. For class C2 or C1 environments, an additional external filter may be required. An internal wire link may be easily removed to disconnect the Y capacitors for those installations where earth currents are undesirable.

Order Code

AC20

	1		2	3		4		5	6
Order example	20G	-	1	2	-	0070	-	B	F

1 Device Family

20G AC20 Series, Advanced, General Purpose AC Drive

2 Voltage

1 230 V Single Phase

3 230 V Three Phase

4 480 V Three Phase

3&4 Frame Size & Current Rating (Heavy Duty)

230VAC, Single Phase Supply Voltage

2-0070 Frame 2 - 7A (2HP)

2-0100 Frame 2 - 10A (3HP)

230VAC, Three Phase Supply Voltage

2-0070 Frame 2 - 7A (2HP)

2-0100 Frame 2 - 10A (3HP)

3-0170 Frame 3 - 17A (5HP)

4-0210 Frame 4 - 21A (7.5HP)

5-0300 Frame 5 - 30A (10HP)

5-0400 Frame 5 - 40A (15HP)

480VAC, Three Phase Supply Voltage

2-0040 Frame 2 - 3.5A (2HP)

2-0065 Frame 2 - 5.7A (3HP)

2-0090 Frame 2 - 7.8A (5HP)

3-0120 Frame 3 - 10A (7.5HP)

3-0170 Frame 3 - 15A (10HP)

4-0230 Frame 4 - 20A (15HP)

4-0320 Frame 4 - 28A (20HP)

5-0380 Frame 5 - 33A (25HP)

5-0440 Frame 5 - 38A (30HP)

5-0600 Frame 5 - 52A (40HP)

6-0750 Frame 6 - 65A (50HP)

6-0900 Frame 6 - 78A (60HP)

7-1100 Frame 7 - 96A (75HP)

7-1500 Frame 7 - 130A (100HP)

8-1800 Frame 8 - 157A (125HP)

8-2200 Frame 8 - 191A (150HP)

8-2650 Frame 8 - 230A (200HP)

10-3600 Frame 10 - 313A (250HP)

5 Brake Switch

B Brake Switch Installed

6 EMC Filter

F Category C3 Filtered

Parker Worldwide

AE – UAE, Dubai

Tel: +971 4 8127100
parker.me@parker.com

AR – Argentina, Buenos Aires

Tel: +54 3327 44 4129

AT – Austria, Wiener Neustadt

Tel: +43 (0)2622 23501-0
parker.austria@parker.com

AT – Eastern Europe, Wiener Neustadt

Tel: +43 (0)2622 23501 900
parker.easteurope@parker.com

AU – Australia, Castle Hill

Tel: +61 (0)2-9634 7777

AZ – Azerbaijan, Baku

Tel: +994 50 2233 458
parker.azerbaijan@parker.com

BE/LU – Belgium, Nivelles

Tel: +32 (0)67 280 900
parker.belgium@parker.com

BR – Brazil, Cachoeirinha RS

Tel: +55 51 3470 9144

BY – Belarus, Minsk

Tel: +375 17 209 9399
parker.belarus@parker.com

CA – Canada, Milton, Ontario

Tel: +1 905 693 3000

CH – Switzerland, Etoy

Tel: +41 (0)21 821 87 00
parker.switzerland@parker.com

CL – Chile, Santiago

Tel: +56 2 623 1216

CN – China, Shanghai

Tel: +86 21 2899 5000

CZ – Czech Republic, Klecany

Tel: +420 284 083 111
parker.czechrepublic@parker.com

DE – Germany, Kaarst

Tel: +49 (0)2131 4016 0
parker.germany@parker.com

DK – Denmark, Ballerup

Tel: +45 43 56 04 00
parker.denmark@parker.com

ES – Spain, Madrid

Tel: +34 902 330 001
parker.spain@parker.com

FI – Finland, Vantaa

Tel: +358 (0)20 753 2500
parker.finland@parker.com

FR – France, Contamine s/Arve

Tel: +33 (0)4 50 25 80 25
parker.france@parker.com

GR – Greece, Athens

Tel: +30 210 933 6450
parker.greece@parker.com

HK – Hong Kong

Tel: +852 2428 8008

HU – Hungary, Budapest

Tel: +36 1 220 4155
parker.hungary@parker.com

IE – Ireland, Dublin

Tel: +353 (0)1 466 6370
parker.ireland@parker.com

IN – India, Mumbai

Tel: +91 022 4124 2500
reception.india@parker.com

IT – Italy, Corsico (MI)

Tel: +39 02 45 19 21
parker.italy@parker.com

JP – Japan, Tokyo

Tel: +81 (0)3 6408 3901

KR – South Korea, Seoul

Tel: +82 2 559 0400

KZ – Kazakhstan, Almaty

Tel: +7 7272 505 800
parker.easteurope@parker.com

LV – Latvia, Riga

Tel: +371 6 745 2601
parker.latvia@parker.com

MX – Mexico, Apodaca

Tel: +52 81 8156 6000

MY – Malaysia, Shah Alam

Tel: +60 3 7849 0800

NL – The Netherlands, Oldenzaal

Tel: +31 (0)541 585 000
parker.nl@parker.com

NO – Norway, Ski

Tel: +47 64 91 10 00
parker.norway@parker.com

NZ – New Zealand, Mt Wellington

Tel: +64 9 574 1744

PL – Poland, Warsaw

Tel: +48 (0)22 573 24 00
parker.poland@parker.com

PT – Portugal, Leca da Palmeira

Tel: +351 22 999 7360
parker.portugal@parker.com

RO – Romania, Bucharest

Tel: +40 21 252 1382
parker.romania@parker.com

RU – Russia, Moscow

Tel: +7 495 645-2156
parker.russia@parker.com

SE – Sweden, Spånga

Tel: +46 (0)8 59 79 50 00
parker.sweden@parker.com

SG – Singapore

Tel: +65 6887 6300

SK – Slovakia, Banská Bystrica

Tel: +421 484 162 252
parker.slovakia@parker.com

SL – Slovenia, Novo Mesto

Tel: +386 7 337 6650
parker.slovenia@parker.com

TH – Thailand, Bangkok

Tel: +662 717 8140

TR – Turkey, Istanbul

Tel: +90 216 4997081
parker.turkey@parker.com

TW – Taiwan, Taipei

Tel: +886 2 2298 8987

UA – Ukraine, Kiev

Tel: +380 44 494 2731
parker.ukraine@parker.com

UK – United Kingdom, Warwick

Tel: +44 (0)1926 317 878
parker.uk@parker.com

US – USA, Cleveland

Tel: +1 216 896 3000

VE – Venezuela, Caracas

Tel: +58 212 238 5422

ZA – South Africa, Kempton Park

Tel: +27 (0)11 961 0700
parker.southafrica@parker.com

