

T-slotted slidable clamp with compact body and large clamping stroke, equipped with a strong clamping force and high rigidity to resist shock.

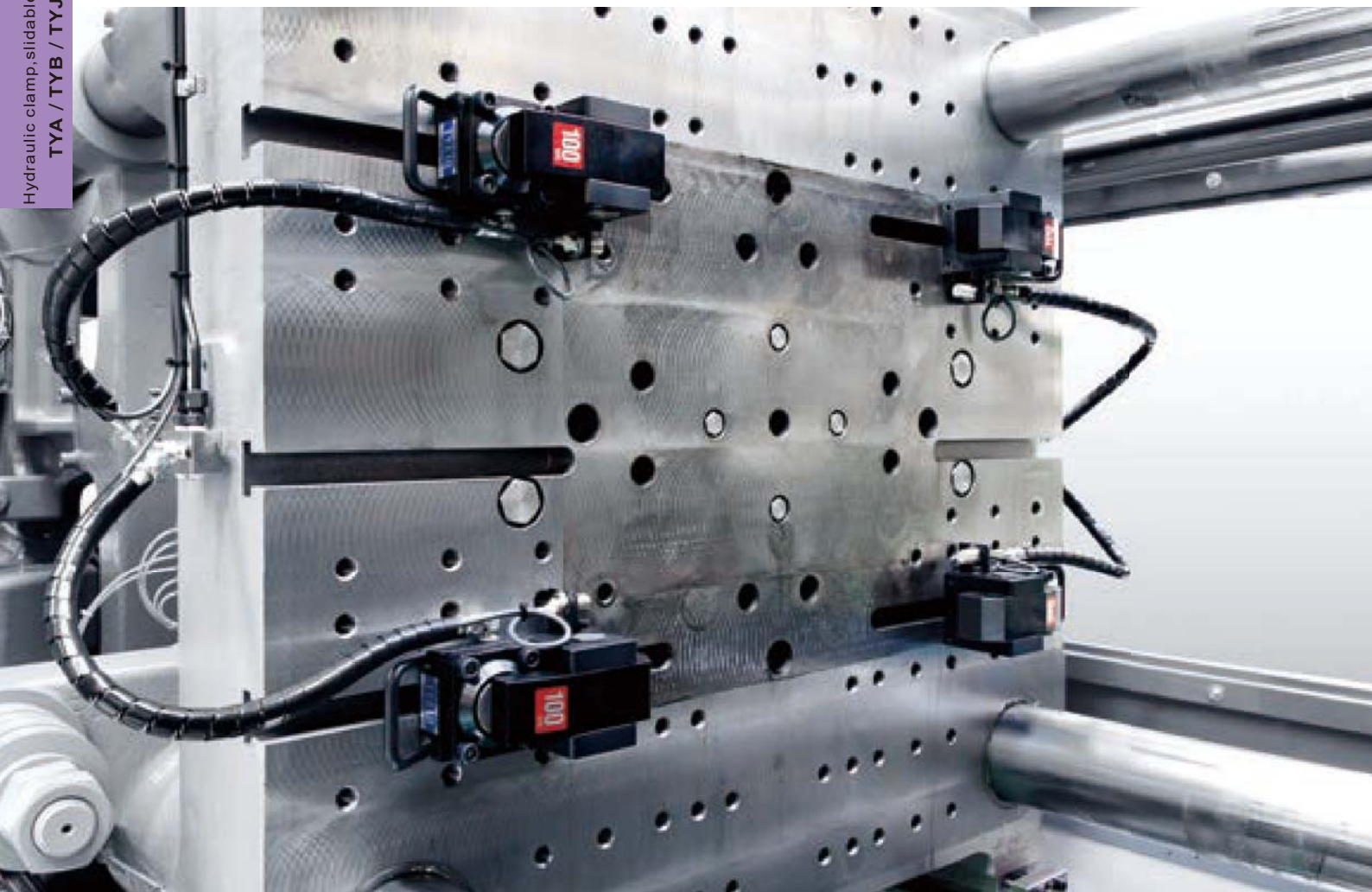

4,500kN (450ton) IMM vertical loading Hydraulic clamp, slidable type TYA



model **TYA**

Standard type

page → 28



model **TYB**

Long stroke type

The **max. 5mm** (in case of using a lever spacer, **max. 15mm**) of dimensional variation can be absorbed.

page → 29



model **TYJ**

Long stroke type

The **max. 10mm** of dimensional variation can be absorbed.

page → 30

• Standard type



model **TYA**

■ Model designation **TYA 020**

■ Option

Refer to page → 34

1 Clamping force

TYA & Die setter

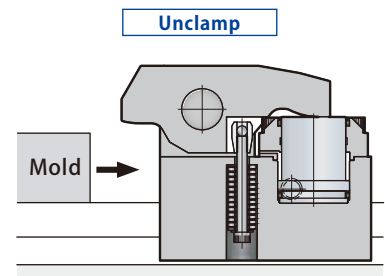
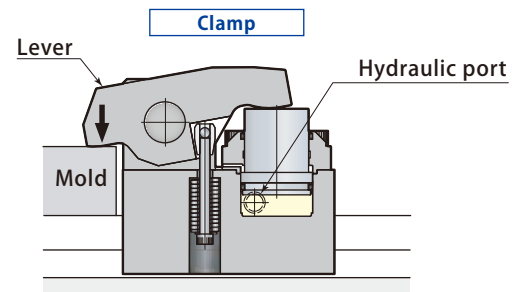
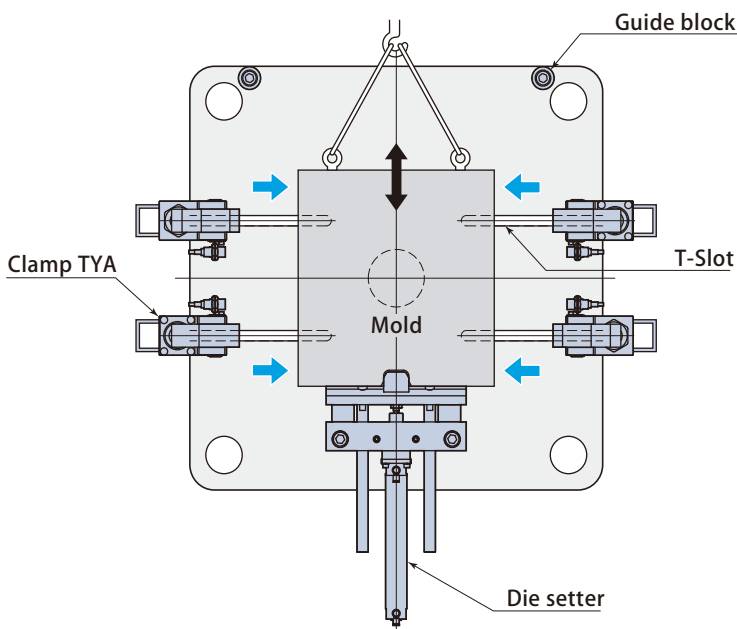

It is mounted on the T-slot and slid manually.

1 Specifications

Model		TYA010	TYA020	TYA040	TYA063	TYA100	TYA160	TYA250
Clamping force (at 24.5 MPa)	kN	9.8	19.6	39.2	61.7	98	156	245
Full stroke	mm	6	7	7	8	8	8	8
Clamping stroke	mm	3	4	4	4	4	4	4
Safety stroke	mm	3	3	3	4	4	4	4
Cylinder capacity (at full stroke)	cm ³	2.4	6.3	13.2	22.3	37	61	93
Proof pressure	MPa	36.7						
Working hydraulic pressure	MPa	24.5						
Operating temperature	°C	0 ~ 70 (5 ~ 120 by heat proof type)						
Weight	kg	1	3	4.5	9	15	25	35

- Safety stroke and clamping stroke shown above are subject to change depending on dimensions of mold and T-slot.
- Weight varies according to the dimension of clamp T-leg and mold plate thickness h.
- Refer to page → 67 for the details of cutout dimensions on mold.

- Long stroke type
- The max. **5mm** (in case of using a lever spacer, max. **15mm**) of dimensional variation can be absorbed.



model **TYB**

■ Model designation **TYB 040**

■ Option

Refer to page → 34

1 Clamping force

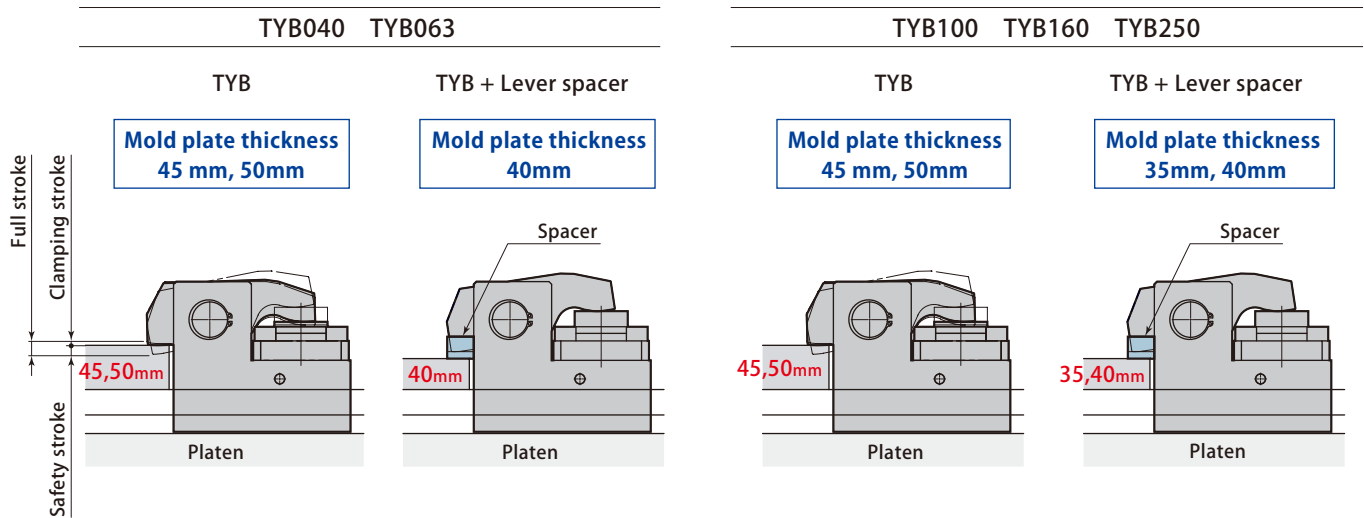

TYB + Lever spacer

- In case that the dimensional variation of mold plate thickness is over -10mm, add the lever spacer.

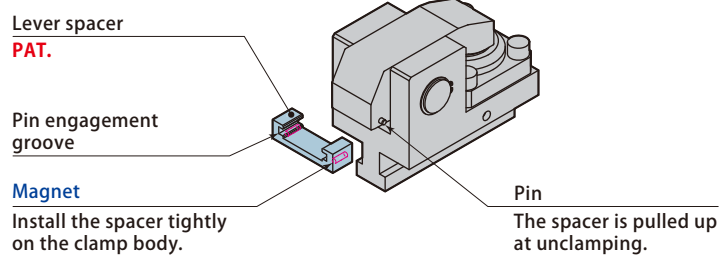

1 Specifications

Model		TYB040	TYB063	TYB100	TYB160	TYB250
Clamping force (at 24.5 MPa)	kN	39.2	61.7	98.0	156	245
Full stroke	mm	10	10	12	12	12
Clamping stroke	mm	4	4	4	4	4
Safety stroke	mm	6	6	8	8	8
Cylinder capacity (at full stroke)	cm ³	16.5	26.1	47.2	78.2	130
Proof pressure	MPa	36.7				
Working hydraulic pressure	MPa	24.5				
Operating temperature	°C	0 ~ 70 (5 ~ 120 by heat proof type)				
Weight	kg	4.5	9	15	25	45

- Safety stroke and clamping stroke shown above are subject to change depending on dimensions of mold and T-slot.
- Weight varies according to the dimension of clamp T-leg and mold plate thickness h.

- Long stroke type
- **The max.10mm** lever stroke can accommodate dimensional variation of clamping height.



model **TYJ PAT.**

■ Model designation **TYJ 063**

■ Option

Refer to page → 34

1 Clamping force

Hydraulic clamp, long stroke slidable type TYJ

Mold plate thickness 50mm

Mold plate thickness 45mm

Mold plate thickness 40mm

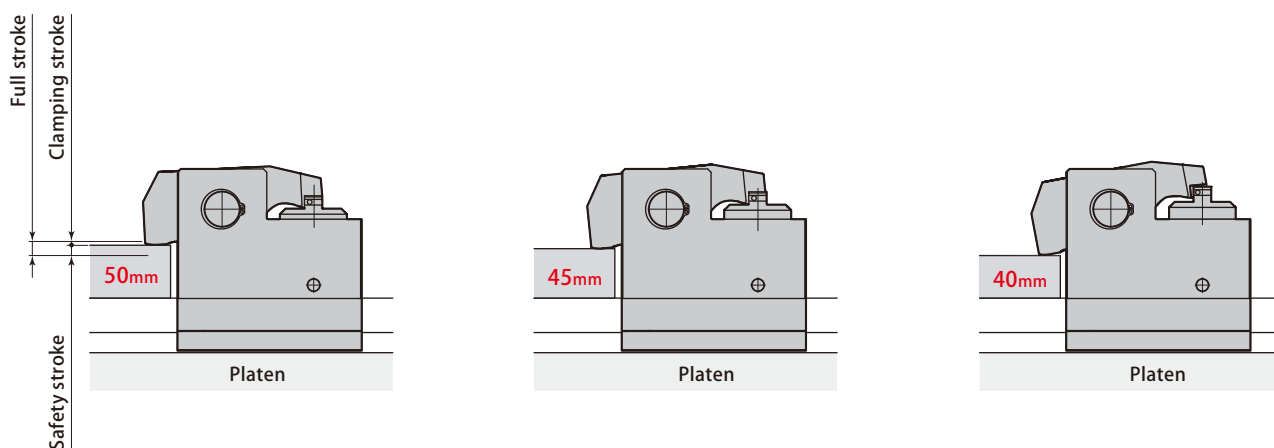

1 Specifications

Model		TYJ063	TYJ100	TYJ160	TYJ250
Clamping force (at 24.5 MPa)	kN	61.7	98	156	245
Full stroke	mm	14	15	16	16
Clamping stroke	mm	1	1	2	2
Safety stroke	mm	13	14	14	14
Cylinder capacity (at full stroke)	cm ³	34	58	97	167
Proof pressure	MPa	30.8			
Working hydraulic pressure	MPa	24.5			
Operating temperature	°C	0 ~ 70 (5 ~ 120 by heat proof type)			
Weight	kg	9	15	25	45

- Safety stroke and clamping stroke shown above are subject to change depending on dimensions of mold and T-slot.
- Weight varies according to the dimension of clamp T-leg and mold plate thickness h.

Dimensions

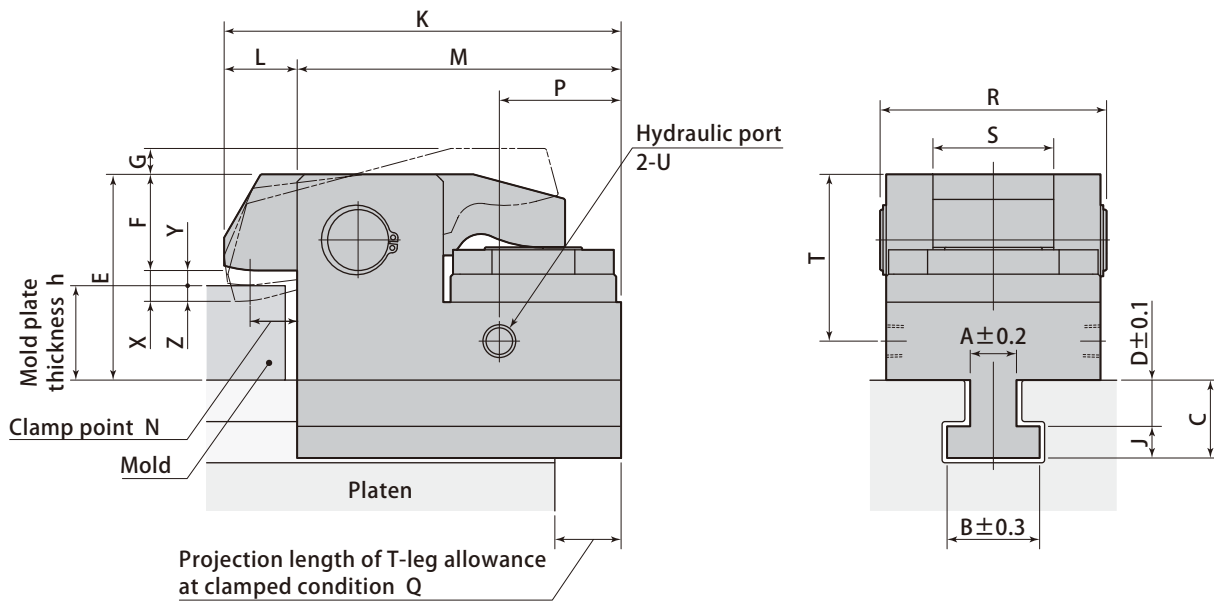

T-slot dimension and mold plate thickness

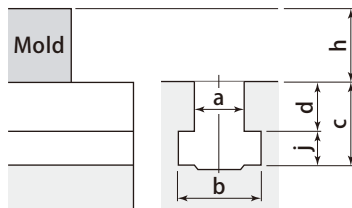

- Specify T-slot dimensions (a, b, c, d, j) and mold plate thickness (h).
- For "d" dimension of T-slot
For retrofit : Specify to 0.1 mm
For new machine : Machining tolerance shall be ± 0.2 mm
- Dimensions (A, B, C, D, J) shall be determined according to T-slot dimensions.

mm

Model	TYA010	TYA020	TYA040	TYA063	TYA100	TYA160	TYA250
Height of lever F	16.5(25 ≤ h)	17.5(32.5 ≤ h)	27.5(38 ≤ h)	29.5(48 ≤ h)	45 (58 ≤ h)	60 (68 ≤ h)	76 (88 ≤ h)
range of h inside the brackets	21.5(20 ≤ h < 25)	22.5(27.5 ≤ h < 32.5)	32.5(33 ≤ h < 38)	39.5(38 ≤ h < 48)	55(48 ≤ h < 58)	70(58 ≤ h < 68)	86(78 ≤ h < 88)
	26.5(15 ≤ h < 20)	27.5(22.5 ≤ h < 27.5)	37.5(28 ≤ h < 33)	49.5(28 ≤ h < 38)	65(38 ≤ h < 48)	80(48 ≤ h < 58)	96(68 ≤ h < 78)
Max. G	6	10	10	10	11	12	13
K	73	101	143	163	195	230	270
L	15	18	23	30	30	30	30
M	58	83	120	133	165	200	240
N	10	12.5	16	20	20	20	20
P	31	41	32.5	36	62	80	90
Projection length of T-leg allowance at clamped condition Q	18	22	32	36	45	55	69
R	46.4	57.6	73	93	104	125	155
S	20	28	40	50	55	60	72
T	34.5	43	57.5	68.5	97	120	156
Hydraulic port U	Rc1/8	Rc1/4	Rc1/4	Rc1/4	Rc1/4	Rc1/4	Rc1/4
Min. E	44.5	54	69.5	81.5	107	132	168
Full stroke X	6	7	7	8	8	8	8
Clamping stroke Y	3	4	4	4	4	4	4
Safety stroke Z	3	3	3	4	4	4	4
Min. j	8	9.5	11.5	15	17	20	23
h (Min. ~ Max.)	15 ~ 50	22.5 ~ 50	28 ~ 50	28 ~ 60	38 ~ 70	48 ~ 80	68 ~ 80
Min. a	10	12.5	15	19	23	27	32
Min. C	15	25.5	32.5	35.5	32	34	30

- When newly machining T-slot, it is recommended to apply the dimensions specified on [page → 67](#).
- Height of lever F varies according to the dimension of h.
- In case of smaller than the minimum h dimension or the minimum C dimension, it is **Clamp lever low distance type**.
- In case of larger than the maximum h dimension, it is **Clamp lever high distance type**.
- Depending on T-slot dimension, TYA can be used more than maximum Q. Contact Pascal for the details.

Dimensions

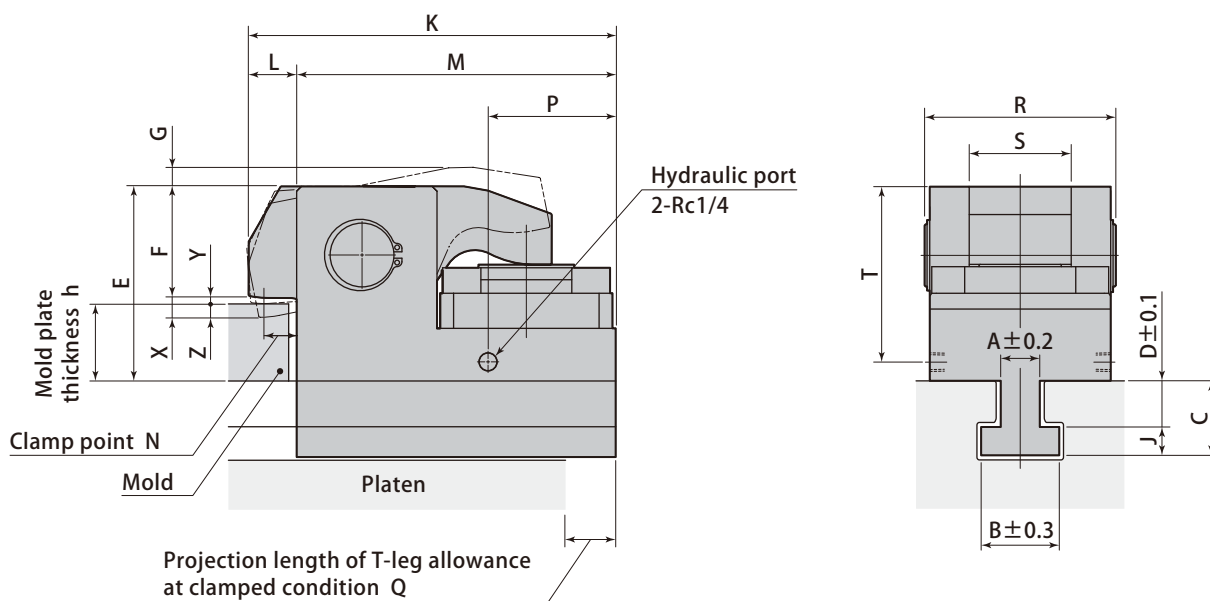

T-slot dimension and mold plate thickness

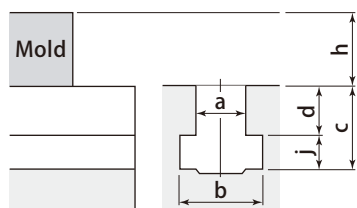

- Specify T-slot dimensions (a, b, c, d, j) and mold plate thickness (h).
- For "d" dimension of T-slot
For retrofit : Specify to 0.1 mm
For new machine : Machining tolerance shall be ±0.2 mm
- Dimensions (A, B, C, D, J) shall be determined according to T-slot dimensions.

Model	TYB040	TYB063	TYB100	TYB160	TYB250
Height of lever F range of h inside the brackets	27.5 (45 ≤ h)	29.5 (50 ≤ h)	45 (58 ≤ h)	60 (58 ≤ h)	106 (58 ≤ h)
	32.5 (40 ≤ h < 45)	39.5 (40 ≤ h < 50)	55 (48 ≤ h < 58)	70 (48 ≤ h < 58)	116 (48 ≤ h < 58)
	37.5 (35 ≤ h < 40)	49.5 (30 ≤ h < 40)	65 (38 ≤ h < 48)	80 (38 ≤ h < 48)	126 (38 ≤ h < 48)
Max. G	10	10	11	12	16
K	143	163	195	230	280
L	23	30	30	30	35
M	120	133	165	200	245
N	16	20	20	20	20
P	32.5	38	62	80	95
Projection length of T-leg allowance at clamped condition Q	32	36	45	55	65
R	73	93	104	125	155
S	40	50	55	60	72
T	64.5	71.5	94.5	110	156
Min. E	76.5	83.5	107	122	168
Full stroke X	10	10	12	12	12
Clamping stroke Y	4	4	4	4	4
Safety stroke Z	6	6	8	8	8
Min. j	11.5	15	17	20	27
h (Min. ~ Max.)	35 ~ 50	30 ~ 60	38 ~ 70	38 ~ 70	38 ~ 70
Min. a	15	19	23	27	32
Min. C	17.1	23.1	27	39	35

● When newly machining T-slot, it is recommended to apply the dimensions specified on page → 67. ● Height of lever F varies according to the dimension of h. ● In case of smaller than the minimum h dimension or the minimum C dimension, it is **Clamp lever low distance type**. ● In case of larger than the maximum h dimension, it is **Clamp lever high distance type**. ● Depending on T-slot dimension, TYA can be used more than maximum Q. Contact Pascal for the details.

Dimensions

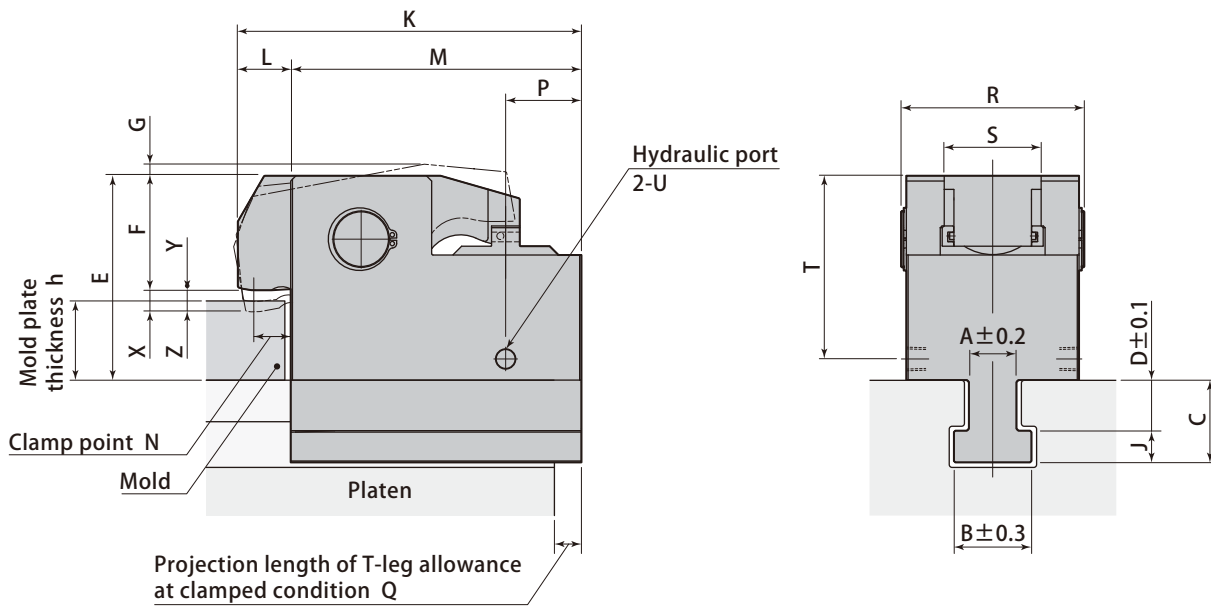

T-slot dimension and mold plate thickness

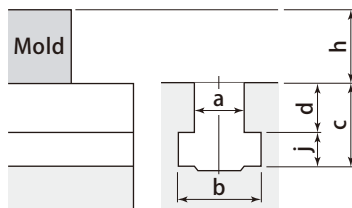

- Specify T-slot dimensions (a, b, c, d, j) and mold plate thickness (h).
- For "d" dimension of T-slot
For retrofit : Specify to 0.1 mm
For new machine : Machining tolerance shall be ±0.2 mm
- Dimensions (A, B, C, D, J) shall be determined according to T-slot dimensions.

Model	TYJ063	TYJ100	TYJ160	TYJ250
Height of lever F	39.5 (50 ≤ h)	55 (60 ≤ h)	70 (60 ≤ h)	96 (65 ≤ h)
range of h inside the brackets	49.5 (40 ≤ h < 50)	65 (50 ≤ h < 60)	80 (50 ≤ h < 60)	106 (55 ≤ h < 65)
	59.5 (30 ≤ h < 40)	75 (40 ≤ h < 50)	90 (40 ≤ h < 50)	116 (45 ≤ h < 55)
Max. G	10	10	11	15
K	163	195	232	275
L	30	30	32	35
M	133	165	200	240
N	18	20	20	22
P	34	43	53	63
Projection length of T-leg allowance at clamped condition Q	34	43	53	63
R	93	104	125	155
S	50	55	60	72
T	78.5	104	120	146
Hydraulic port U	Rc1/4	Rc1/4	Rc1/4	Rc1/4
Min. E	90.5	116	132	163
Full stroke X	14	15	16	16
Clamping stroke Y	1	1	2	2
Safety stroke Z	13	14	14	14
Min. j	15	17	20	27
h (Min. ~ Max.)	30 ~ 60	40 ~ 70	40 ~ 80	45 ~ 85
Min. a	19	23	27	32

mm

- When newly machining T-slot, it is recommended to apply the dimensions specified on page → 67.
- Height of lever F varies according to the dimension of h.
- In case of smaller than the minimum h dimension, it is **Clamp lever low distance type**.
- In case of larger than the maximum h dimension, it is **Clamp lever high distance type**.
- Depending on T-slot dimension, TYA can be used more than maximum Q. Contact Pascal for the details.

TYA / TYB / TYJ

G With handle TYA□-G

Only TYA040 ~ 250.
It does not correspond to TYA010 and TYA020.

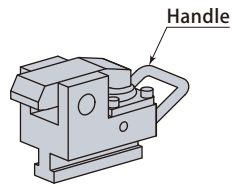

E With mold detection proximity switch

TYA□E0, E1, E2, E3

It prevents clamp misplace.

- TYA□E0** : DC24V 2-Wire
- TYA□E1** : DC24V 3-Wire (NPN)
- TYA□E2** : AC100V 2-Wire
- TYA□E3** : DC24V 3-Wire (PNP)

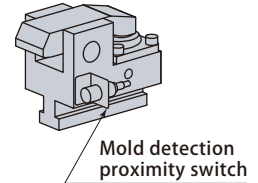

W Wide lever type TYA□-W

It is applied with cut out in the mold.

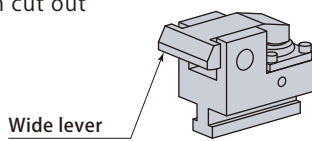

S1 S2 Body strengthened TYA□-S1, TYA□-S2

It is applied under condition that the T-slot dimension is under standard and the strength is insufficient.

- TYA□-S1** : S45C
- TYA□-S2** : SCM435

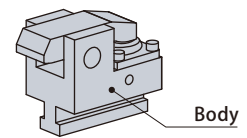

V Heat proof type TYA□-V

It is applied under condition that the mold and its surroundings are in high temperature.

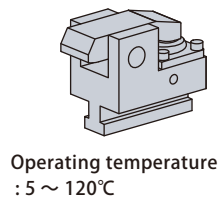

T Low distance clamp type TYA□-T

It is applied under condition that the mold plate thickness is thinner than standard.

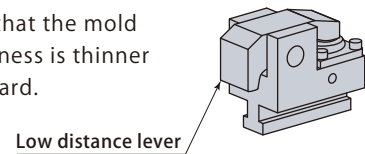

J Rear piping type TYA□-J

It is applied under condition that there is interference on clamp side and it can not be connected with side hydraulic port (standard specification).

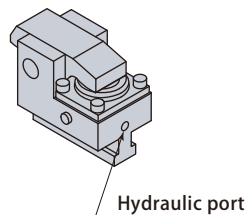

N NPT port TYA□-N

It is applied under condition that hydraulic port is connected with NPT thread.

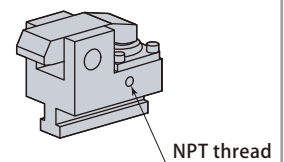

L With lock TYA□-L

It can fix the clamp installed on the position out of reach, such as the opposite operation side.

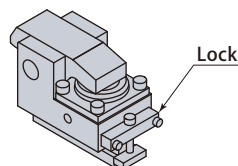

U With mold detection and backward end detection proximity switches

TYA□U0, U1, U2, U3

They prevent clamp misplace at time of mold changing.

- TYA□U0** : DC24V 2-Wire
- TYA□U1** : DC24V 3-Wire (NPN)
- TYA□U2** : AC100V 2-Wire
- TYA□U3** : DC24V 3-Wire (PNP)

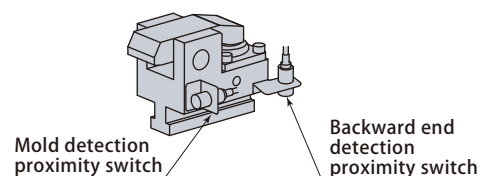

* Option model No. is available for TYB and TYJ.

Automatic slidable clamp with air cylinder. It enables to shorten the mold change time.

Hydraulic clamp, automatic slidable type **TYC-Z/R**

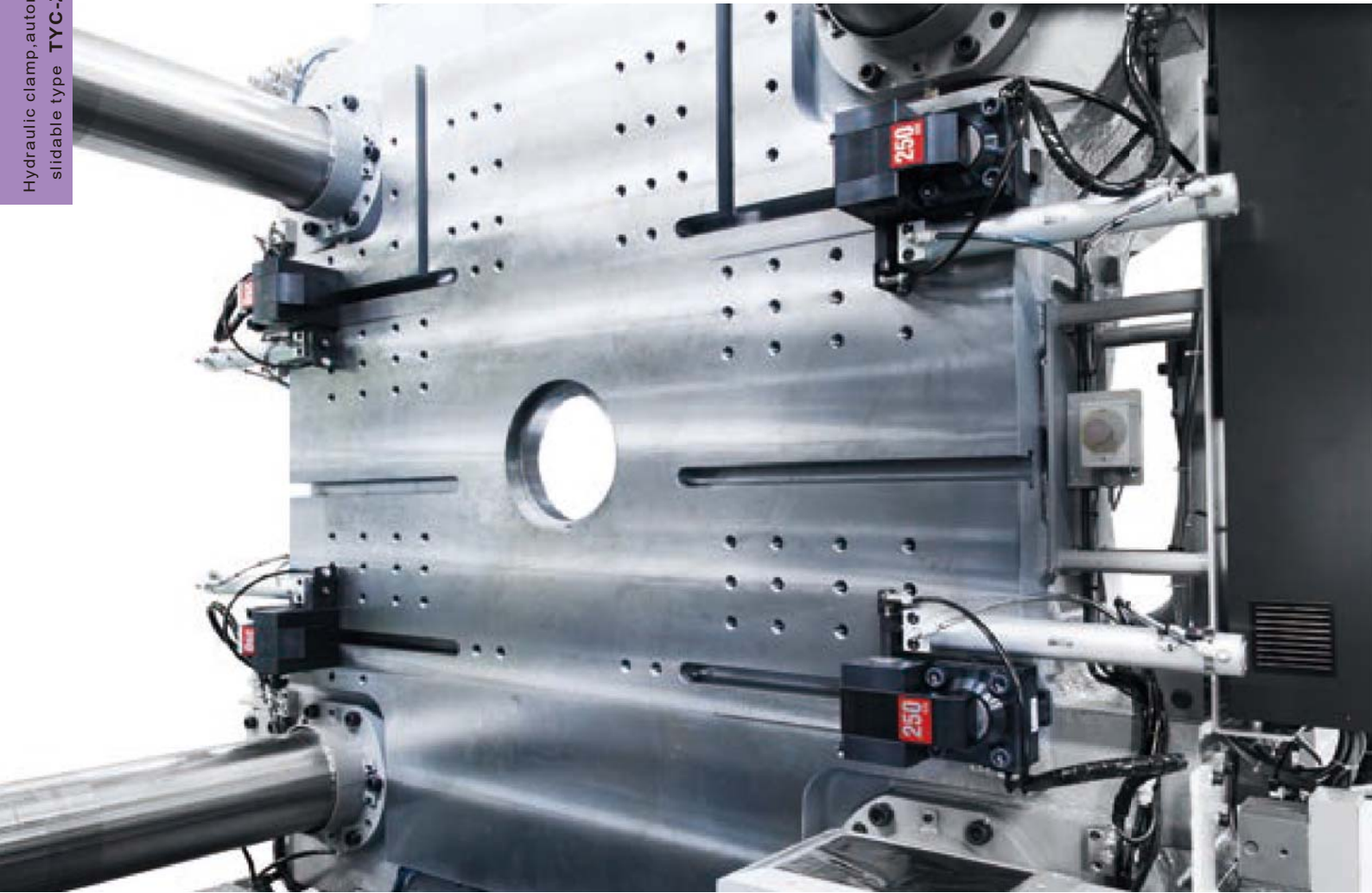

16,000kN (1,600ton) IMM vertical loading Hydraulic clamp, automatic slidable type TYC-Z



model **TYC-Z/R**

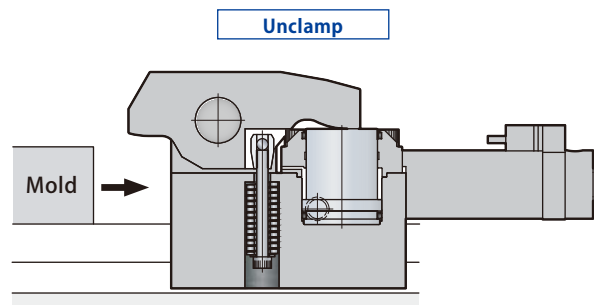
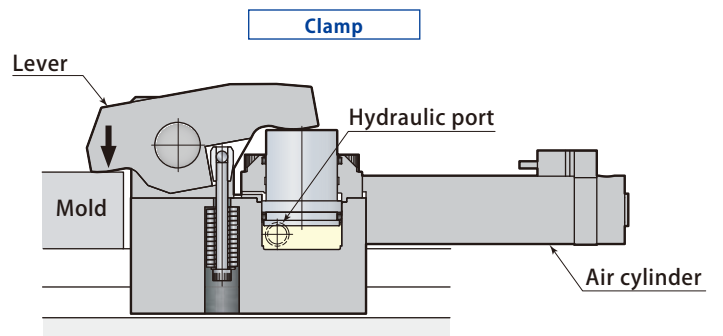

It slides automatically with an air cylinder.

TYC-Z & Die setter

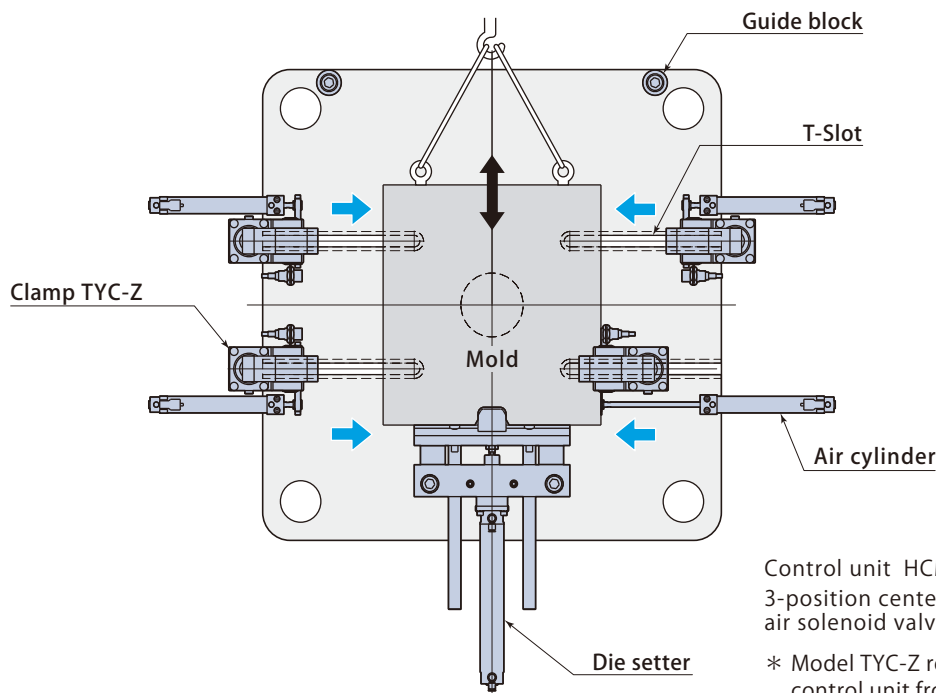

Control unit HCM-T3:
3-position center exhaust
air solenoid valve equipped

* Model TYC-Z requires a different
control unit from that of TYC-R.

■ Model designation **TYC040R0L-075**

- 1 Clamping force
- 6 Slide direction
Z :Horizontal **R** :Vertical
- 2 Proximity switch symbol
page → 38
- 3 Air cylinder position
- 5 Sliding stroke (mm)
* Indicated in 3 digits

3 Air cylinder position

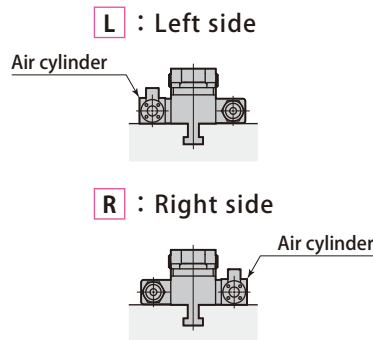

■ Option

- J** Rear piping type
- S1** Body strengthened (S45C)
- S2** Body strengthened (SCM435)
- T** Low distance clamp type
- V** Heat proof type
- W** Wide lever type
- Long stroke slidable type hydraulic clamp**
model **TYB-Z/R** model **TYJ-Z/R**

1 5 Specifications

Model		TYC020Z	TYC040Z	TYC063Z	TYC100Z	TYC160Z	TYC250Z
		TYC020R	TYC040R	TYC063R	TYC100R	TYC160R	TYC250R
Clamping force (at 24.5 MPa)	kN	19.6	39.2	61.7	98	156	245
Full stroke	mm	7	7	8	8	8	8
Clamping stroke	mm	4	4	4	4	4	4
Safety stroke	mm	3	3	4	4	4	4
Standard sliding stroke * 1	mm	50, 75, 100, 125, 150		50, 75, 100, 125, 150, 200	50, 75, 100, 125, 150, 200, 250, 300		
Slider driving air pressure	MPa	0.39 ~ 0.54					
Clamp sliding speed	mm/s	30 ~ 80 (Adjusted by speed controller)					
Proof pressure	MPa	36.7					
Working hydraulic pressure	MPa	24.5					
Operating temperature	°C	0 ~ 70 (5 ~ 120 by heat proof type *2)					
Weight	kg	3.5	5	10	16	26	38

● Weight varies according to the dimension of clamp T-leg and mold plate thickness h. ● Refer to page → 67 for the details of cutout dimensions on mold. *1 Contact Pascal for the sliding stroke which is not mentioned above.

*2 Proximity switch and auto switch will not become a heat proof type.

Hydraulic clamp, automatic slidable type **TYC-Z/R**

Dimensions

● The drawings indicate : air cylinder position **R** (Right).

Unclamp

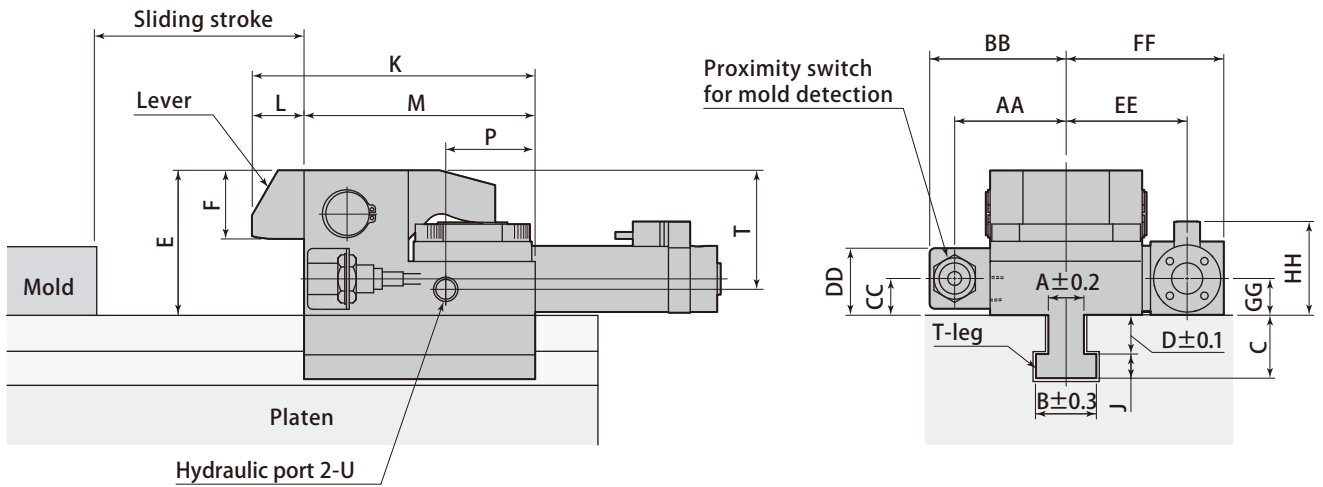
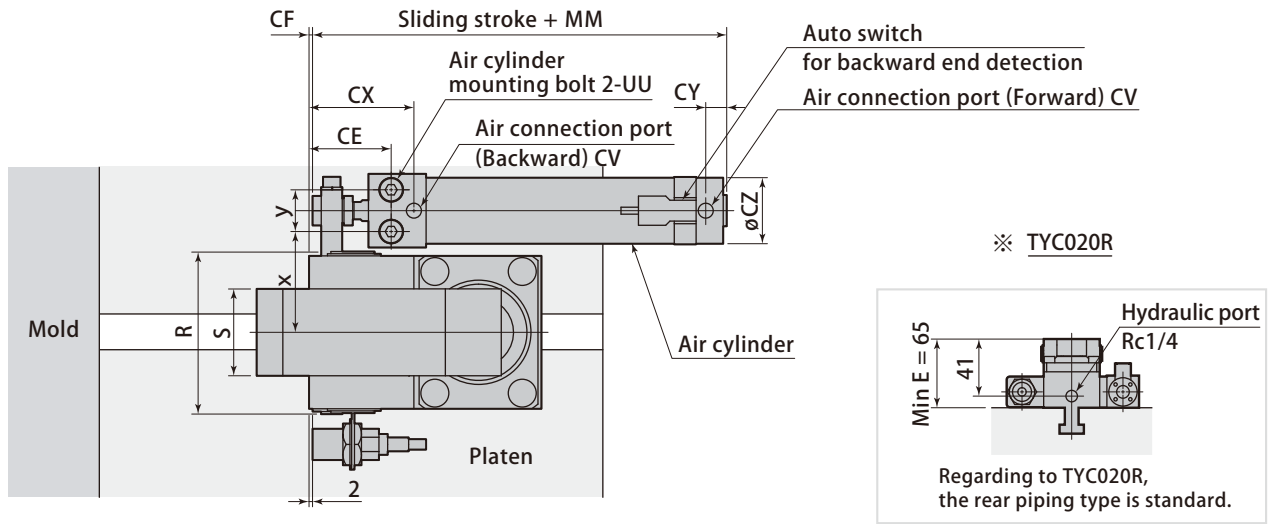

Clamp

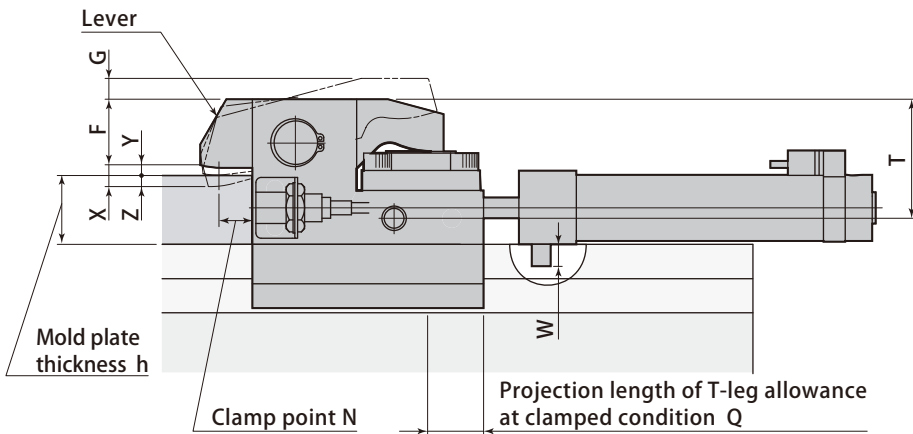

T-slot dimension and mold plate thickness

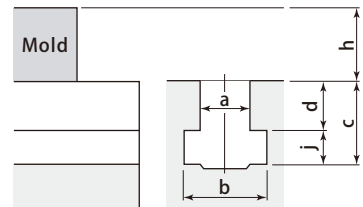

- Specify T-slot dimensions (a, b, c, d, j) and mold plate thickness (h).
- For "d" dimension of T-slot
For retrofit : Specify to 0.1 mm
For new machine : Machining tolerance shall be ±0.2 mm
- Dimensions (A, B, C, D, J) shall be determined according to T-slot dimensions.

Model	TYC020Z	TYC040Z	TYC063Z	TYC100Z	TYC160Z	TYC250Z
	TYC020R	TYC040R	TYC063R	TYC100R	TYC160R	TYC250R
AA	47	54.5	64.5	74	84	98.5
BB	61.5	69	79	89	99	113.5
CC	15	15	21	26	26	32
CE	42.5	42.5	47	57	57	71
CF	2.5	2.5	2	2	2	9
Air connection port CV	Rc1/8	Rc1/8	Rc1/8	Rc1/8	Rc1/8	Rc1/4
CX	51.5	51.5	60	71	71	87
CY	12	12	12	12	12	14
CZ	26	26	38	47	47	58
DD	29.5	29.5	38.5	51	51	63
Min. E	—	69.5	81.5	107	132	168
EE	48.5	56	70	81	91	116
Height of lever F range of h inside the brackets	17.5(32.5≤h)	27.5(38≤h)	29.5(48≤h)	45(58≤h)	60(68≤h)	76(88≤h)
	22.5(27.5≤h<32.5)	32.5(33≤h<38)	39.5(38≤h<48)	55(48≤h<58)	70(58≤h<68)	86(78≤h<88)
	27.5(22.5≤h<27.5)	37.5(28≤h<33)	49.5(28≤h<38)	65(38≤h<48)	80(48≤h<58)	96(68≤h<78)
FF	64.6	72.1	89.5	109	119	153
Max. G	10	10	10	11	12	13
GG	15	15	21	26	26	32
HH	42	42	54	63	63	74
K	101	143	163	195	230	270
L	18	23	30	30	30	30
M	83	120	133	165	200	240
Standard sliding stroke	50, 75, 100, 125, 150		50, 75, 100, 125, 150, 200	50, 75, 100, 125, 150, 200, 250, 300		
MM	108.5	108.5	119	137	137	164
N	12.5	16	20	20	20	20
P	—	32.5	36	62	80	90
Projection length of T-leg allowance at clamped condition Q	22	32	36	45	55	69
R	57.6	73	93	104	125	155
S	28	40	50	55	60	72
T	—	57.5	68.5	97	120	156
Hydraulic port U	—	Rc1/4	Rc1/4	Rc1/4	Rc1/4	Rc1/4
UU	M5	M5	M8	M10	M10	M12
W	9.5	9.5	9.6	12.6	12.6	17
x	39.5	47	58	65	75	95.5
y	18	18	24	32	32	41
Full stroke X	7	7	8	8	8	8
Clamping stroke Y	4	4	4	4	4	4
Safety stroke Z	3	3	4	4	4	4
Min. a	12.5	15	19	23	27	32
Min. j	9.5	11.5	15	17	20	23
h (Min. ~ Max.)	22.5 ~ 50	28 ~ 50	28 ~ 60	38 ~ 70	48 ~ 80	68 ~ 80

Hydraulic clamp, automatic slidable type TYC-Z/R

- When newly machining T-slot, it is recommended to apply the dimensions specified on **page → 67**.
- Height of lever F varies according to the dimension of h.
- In case of smaller than the minimum h dimension, it is **Clamp lever low distance type**.
- In case of larger than the maximum h dimension, it is **Clamp lever high distance type**.
- The position of hydraulic port is subject to change.
- Body height E is subject to change.
- Contact Pascal for the sliding stroke which is not mentioned above.

2 Proximity switch (OMRON)

Proximity switch symbol	0	1	2	3
Switch model	2-Wire DC	3-Wire DC	2-Wire AC	3-Wire DC
	E2E-X7D1-N	E2E-X5E1	E2E-X5Y1	E2E-X5F1
Supply voltage V	DC10 ~ 30	DC10 ~ 40	AC20 ~ 264	DC10 ~ 40
Leakage current mA	0.8 and under	No	1.7 and under	No
Current consumption mA	No	13 and under	No	13 and under
Control output (Switching capacity) mA	3 ~ 100	200	5 ~ 300	200

- Operating temperature : 0 ~ 70°C
- Insulation vinyl cable length : 5m (Oil proof type, 0.5mm²)
- When using Pascal control box, 3-wire DC type (1) shall be delivered.

Auto switch (SMC)

Switch model	D-B54L		
Load voltage V	DC24	AC100	AC200
Range of load current mA	5 ~ 50	5 ~ 25	5 ~ 12.5

- Operating temperature : 0 ~ 70°C
- Insulation vinyl cable length : 3m (Oil proof type, 0.3mm²)

TYA-M

Hydraulic clamp, T-slot-less slidable type

It enables the clamp to slide it manually even if machine platens do not have T-slots.

Hydraulic clamp, T-slot-less slidable type TYA-M

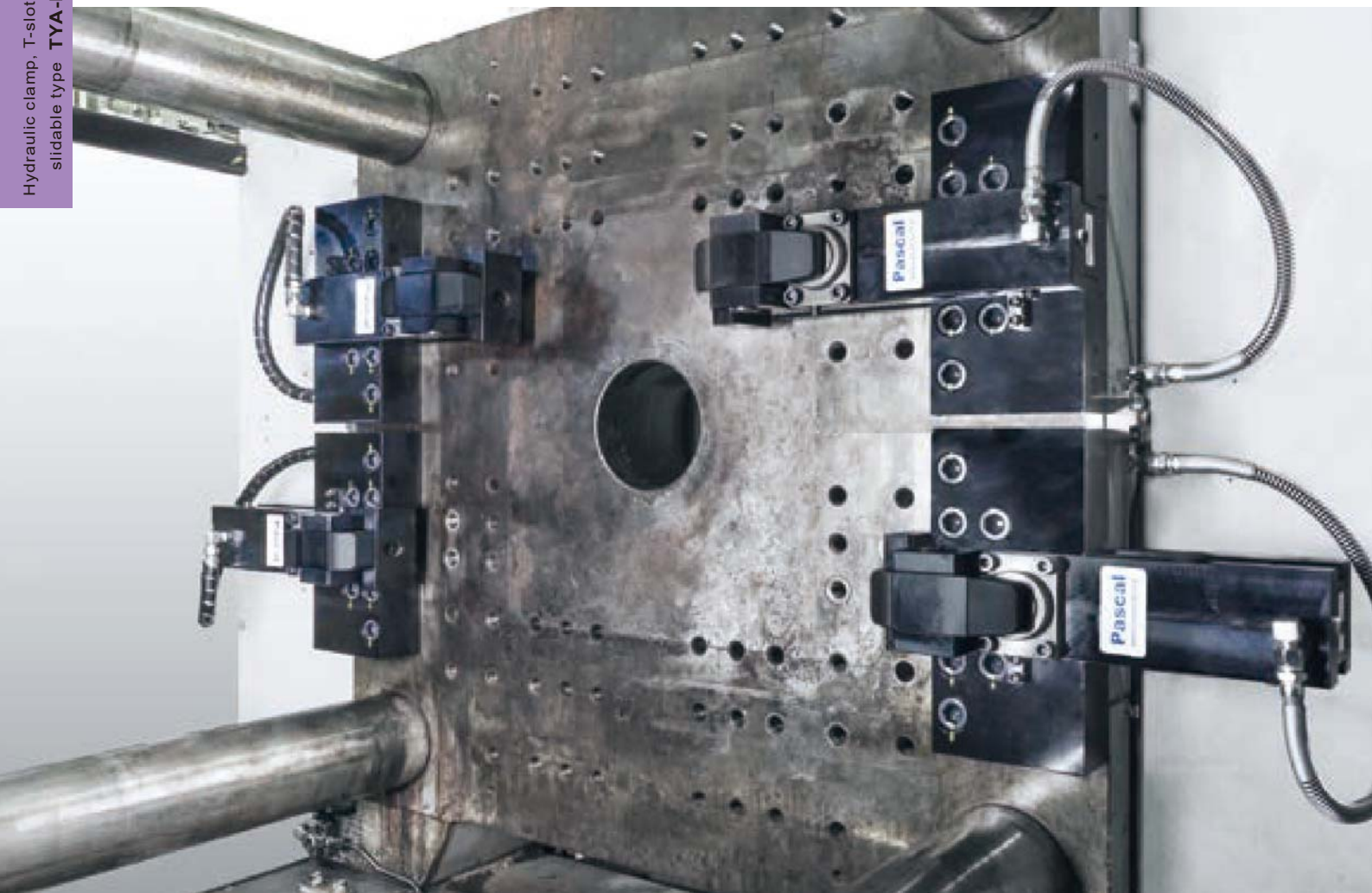

3,500kN (350ton) IMM vertical loading Hydraulic clamp, T-slot-less slidable type TYA-M



model TYA-M

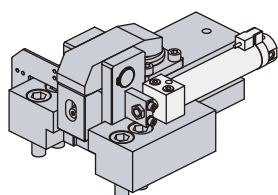

There is also an automatic slidable model with an air cylinder. Please contact Pascal for the details.

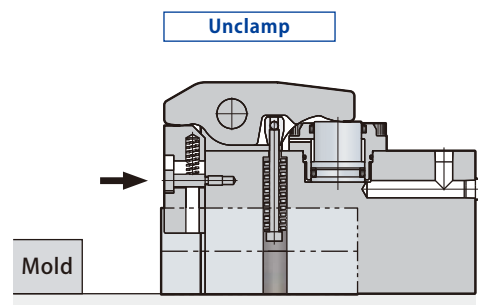
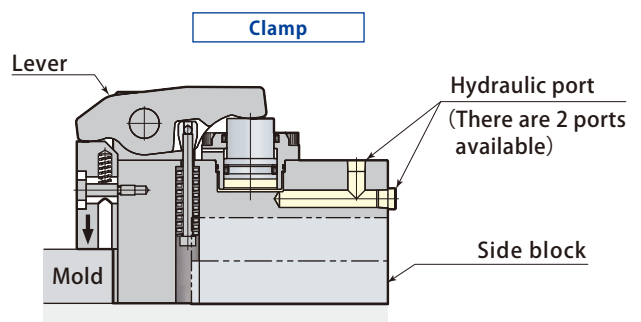

Forward and backward of the clamp itself is manual.

TYA-M & Die setter

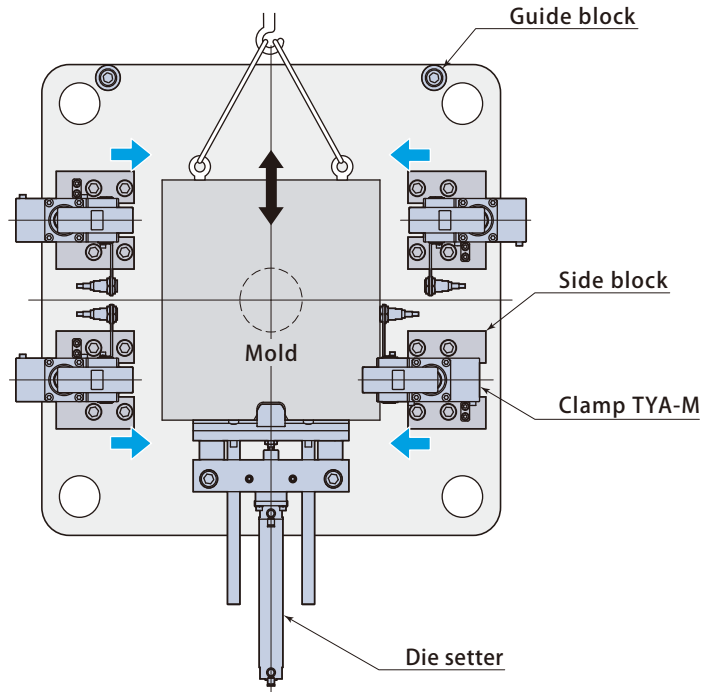

■ Model designation **TYA 040M**

1 Clamping force

■ Option

- 0 ~ 3 With mold detection proximity switch
- G With handle
- S1 Body strengthened (S45C)
- S2 Body strengthened (SCM435)
- V Heat proof type
- T Low distance clamp type
- W Wide lever type

1 Specifications

Model		TYA010M	TYA020M	TYA040M	TYA063M	TYA100M	TYA160M
Clamping force (at 24.5 MPa)	kN	9.8	19.6	39.2	61.7	98	156
Full stroke	mm	6	7	7	8	8	8
Clamping stroke	mm	3	4	4	4	4	4
Safety stroke	mm	3	3	3	4	4	4
Cylinder capacity (at full stroke)	cm ³	2.4	6.3	13.2	22.3	37	61
Standard sliding stroke	mm	12	38	50	50	65	75
Proof pressure	MPa	36.7					
Working hydraulic pressure	MPa	24.5					
Operating temperature	°C	0 ~ 70 (5 ~ 120 by heat proof type)					

- Safety stroke and clamping stroke are subject to change depending on dimensions of mold.
- Weight varies according to the dimension of clamp T-leg and side block.
- Refer to **page → 67** for the details of cutout dimensions on mold.
- If the value of sliding stroke exceeds the above table, please contact Pascal later.

Dimensions

Unclamp

Side block mounting bolt 4-UU

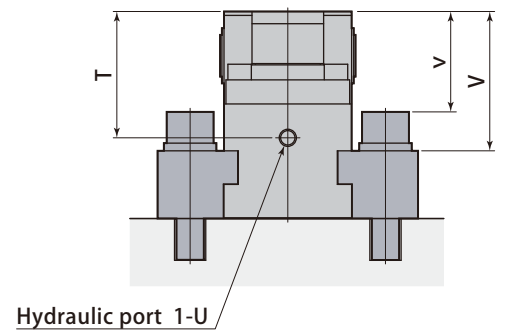
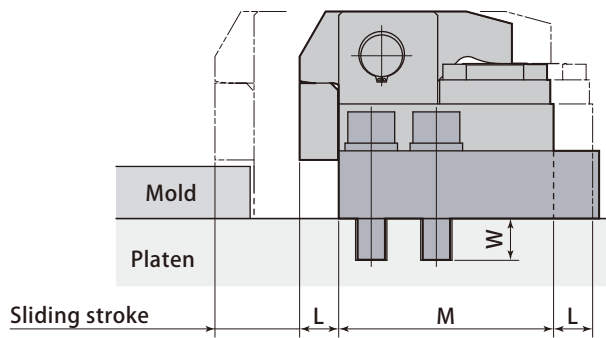
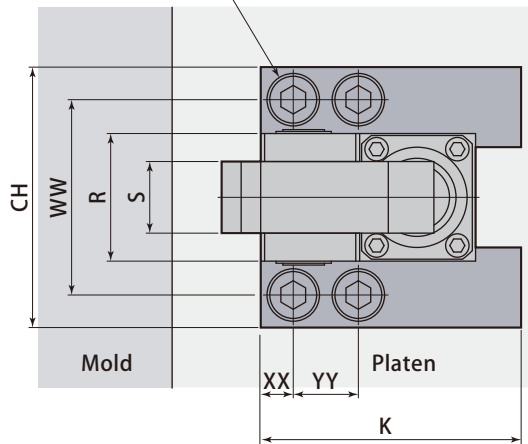

Regarding to TYA-M,
the rear piping type is standard.

Clamp

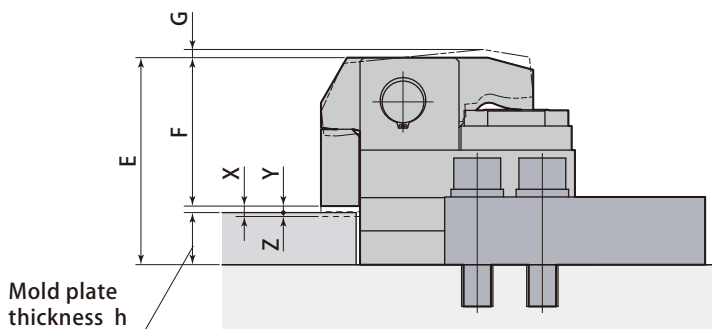

	mm					
Model	TYA010M	TYA020M	TYA040M	TYA063M	TYA100M	TYA160M
CH	105	130	130	160	200	230
E (Case of standard h dimension)	63.5	86.5	106.5	123.5	159	197
F (Case of standard h dimension)	40.5	52.5	72.5	84.5	115	153
Max. G	6	10	10	10	11	12
K	70	100	135	150	200	240
L	15	18	23	30	30	30
M	63	83	120	133	165	200
R	43	53	68	88	98	118
S	20	28	40	50	55	60
T	40.5	54	68	79	97	120
Hydraulic port U	Rc1/8	Rc1/4	Rc1/4	Rc1/4	Rc1/4	Rc1/4
UU	M16 *	M16	M16	M20	M24	M30
v	26	34.5	49.5	56.4	77.1	94.5
V	45.5	54.5	69.5	81.5	107	132
W	23.5	24	24	32.9	32.1	49.1
WW	75	100	100	125	150	175
XX	23	25	25	25	25	30
YY	25	50	50	50	50	60
Standard sliding stroke	12	38	50	50	65	75
Full stroke X	6	7	7	8	8	8
Clamping stroke Y	3	4	4	4	4	4
Safety stroke Z	3	3	3	4	4	4
Standard h	20	30	30	35	40	40

● The above table is reference value. ● CH, K, WW, XX, YY varies according to the installed position of clamp.

● The dimension varies in case of **specification of mold detection prox.switch**. Please contact Pascal later.

* TYA010M utilizes the square spring washer.

It is the clamp with safety and high reliability, which does not lose holding force because of the strong spring even at time of zero hydraulic pressure.

Hydraulic clamp, bolted type TME

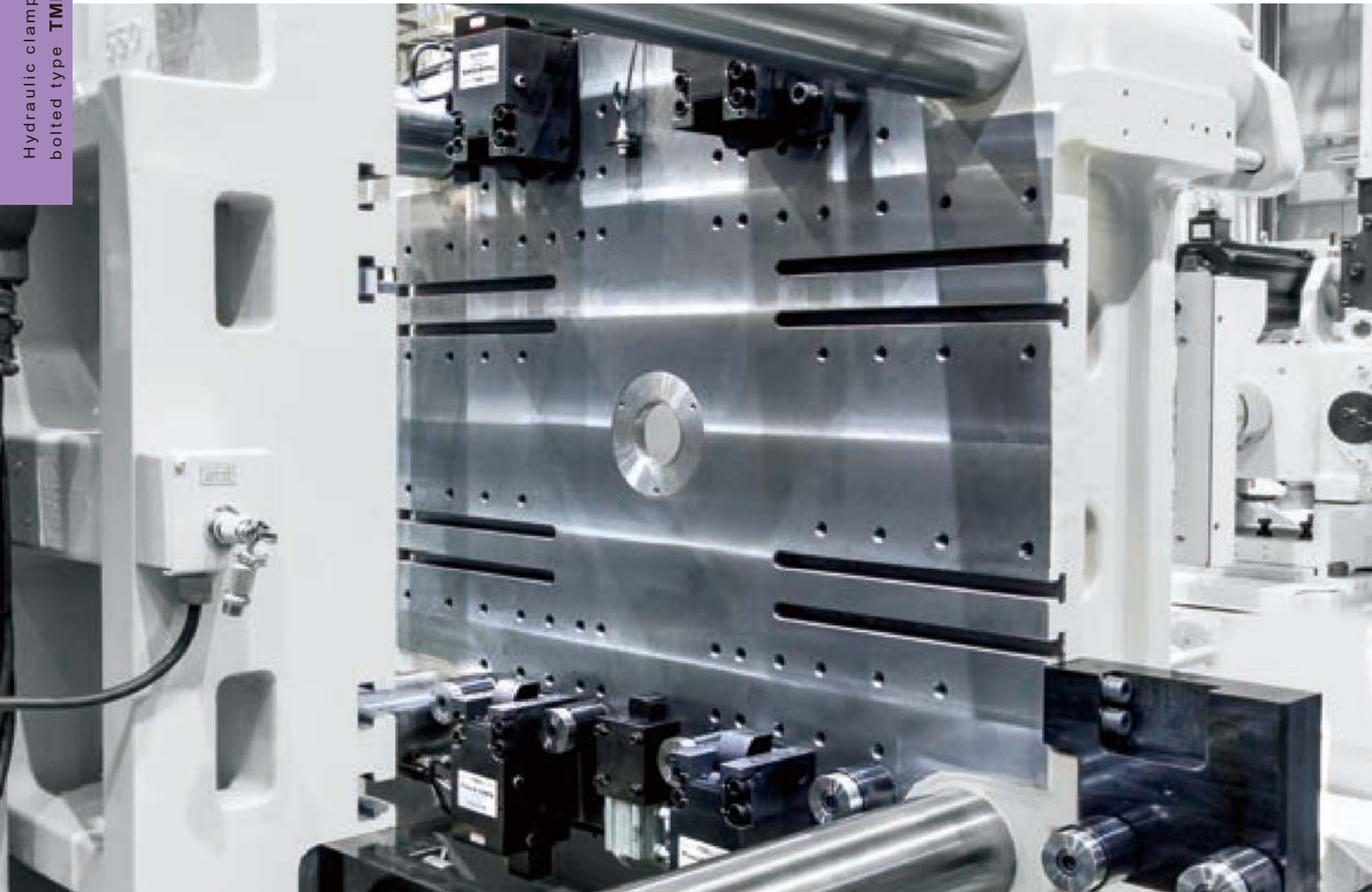

5,500kN (550ton) IMM horizontal loading Hydraulic clamp, bolted type TME



model TME

Clamp

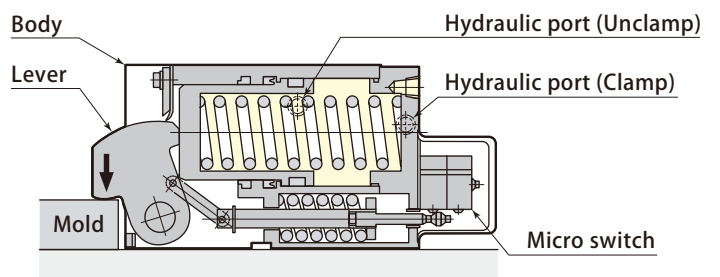

Unclamp

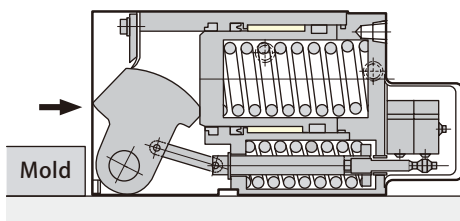

At time of unclamping, the lever is retracted back in the body and it does not interfere in loading/unloading the mold.

TME & Positioning block

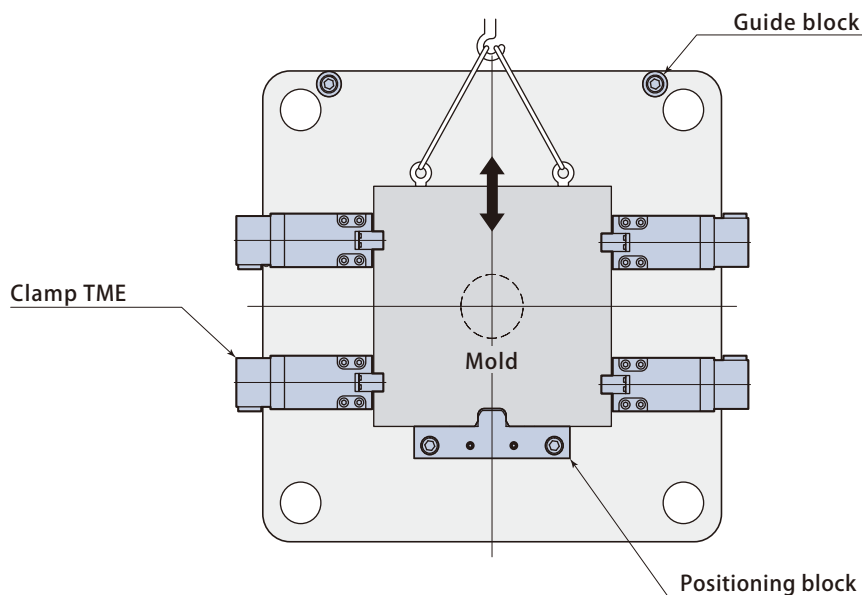

■ Model designation ■ Option

TME025 — □

- S Low distance clamp type
- V Heat proof type

- 1 Holding force
- 4 Mold plate thickness h dimension(mm) **page → 46**

Hydraulic and air pressure circuit

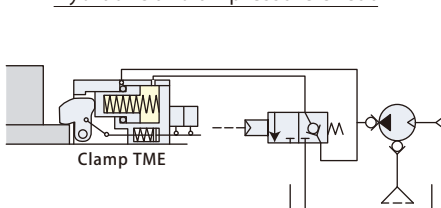

Working hydraulic pressure 15.6 MPa with Pascal non-leak valve

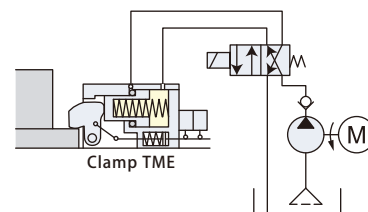

Working hydraulic pressure 13.7 MPa with commercially available valve

1 Specifications

Model		TME010	TME025	TME040	TME063	TME100	TME160	
Holding force	At working hydraulic pressure	kN	9.8	24.5	39.2	61.7	98	156
	At no hydraulic pressure (0MPa)	kN	0.49	0.98	1.56	2.45	3.92	5.88
Clamping force	At working hydraulic pressure	kN	9.8	24.5	39.2	61.7	98	156
Full stroke		mm	3.5	4	4	4	4.5	4.5
Clamping stroke		mm	2	2	2	2	2	2
Safety stroke		mm	1.5	2	2	2	2.5	2.5
Cylinder capacity	Clamp	cm ³	15	41	92	163	298	470
	Unclamp	cm ³	6	11	28	48	87	143
Proof pressure		MPa	20.5					
Working hydraulic pressure (with Pascal non-leak valve)		MPa	15.6					
Working hydraulic pressure (with commercially available valve)		MPa	13.7					
Operating temperature		°C	0 ~ 70					
Weight		kg	3	6	9	15.5	30	55

- The hydraulic pressure required to unclamp is 2.9MPa.
- Refer to **page → 67** for the details of cutout dimensions on mold.

Dimensions

TME 025 ~ 160 -

Mold plate thickness h dimension (mm)

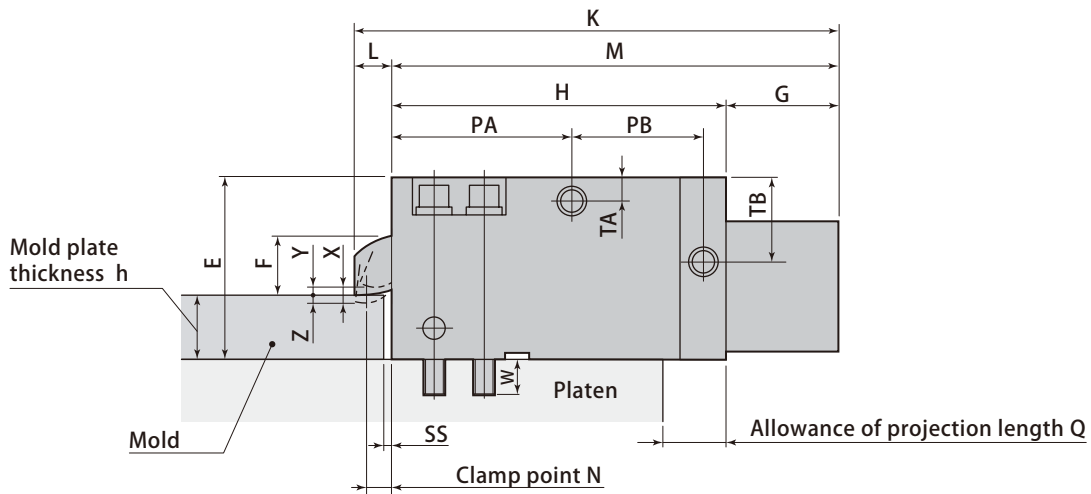
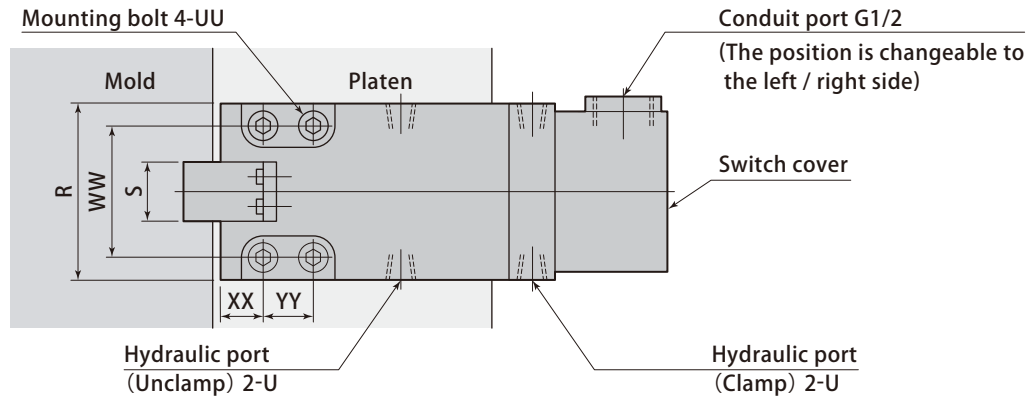

(Position installed of switch cover : left)

TME 010 L -

Mold plate thickness h dimension (mm)

(Position installed of switch cover : right)

TME 010 R -

Mold plate thickness h dimension (mm)

Append of position installed of switch cover only for TME010

Position installed of switch cover left : L right : R

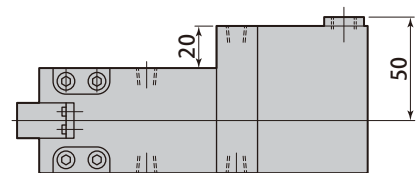
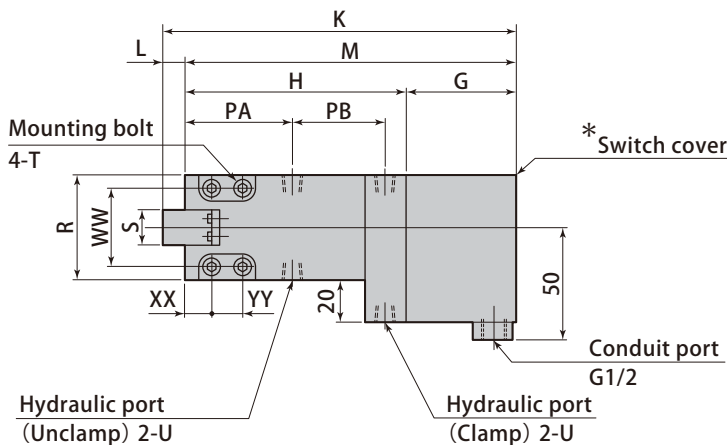

* The form of TME010 differs according to the position installed of switch cover.

	mm					
Model	TME010	TME025	TME040	TME063	TME100	TME160
Min. E	62	86	106	125	152	177
Height of lever F	21	30	39	43	57	78
G	59.5	59.5	59.5	59.5	64	68.5
H	121.5	149.5	180	197	238.5	285
K	132.5	165.5	199	218	263.5	317
L	11	16	19	21	25	32
M	181	209	239.5	256.5	302.5	353.5
N	9	12	14	15	19	20
PA	55.5	74	89	99	121	156.5
PB	56	65.5	80	86	100	108.5
Allowance of projection length Q	24	29	36	39	47	57
R	52	78	88	108	135	182
S	18	27	35	45	55	72
TA	11	15	20	24	30.5	38.5
TB	23.5	31	39	48	61	62
Hydraulic port U	Rc1/8	Rc1/4	Rc1/4	Rc1/4	Rc3/8	Rc3/8
SS	2	3	3	3	3	3
UU	M8	M10	M12	M14	M18	M24
W	17	19	22	24.5	31.4	37
WW	38	58	68	84	106	135
XX	12	17	20	22	30	40
YY	18	22	26	30	36	50
Full stroke X	3.5	4	4	4	4.5	4.5
Clamping stroke Y	2	2	2	2	2	2
Safety stroke Z	1.5	2	2	2	2.5	2.5
4 Min. h *	20	30 (25)	30 (25)	35 (30)	40 (35)	40

* The values in parentheses are for special specification.

Micro switch specifications (OMRON)

Micro switch model	Z-15GD-B	
Rated voltage	V	AC250 DC30
Rated current (Resistance load)	A	15 6

Bolted type of clamp for medium and large size IMM with lever-piston isolation structure.

Hydraulic clamp,
bolted type **TKB**

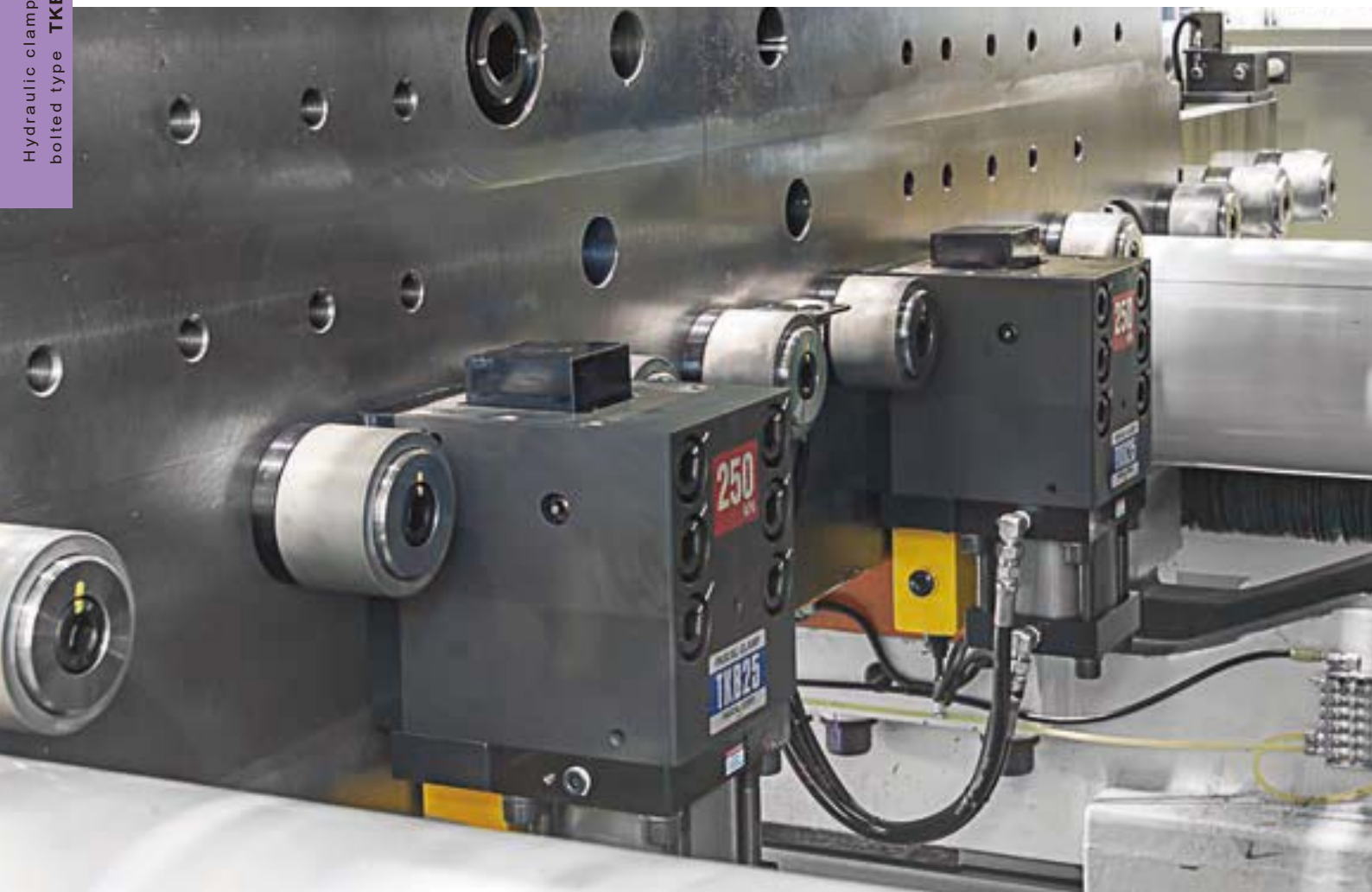

16,000kN (1,600ton) IMM horizontal loading Hydraulic clamp, bolted type TKB



model **TKB**



There is also an automatic slidable model with an air cylinder.
Contact Pascal for the details.

Clamp

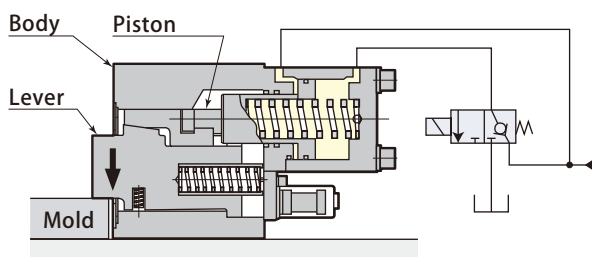

Unclamp

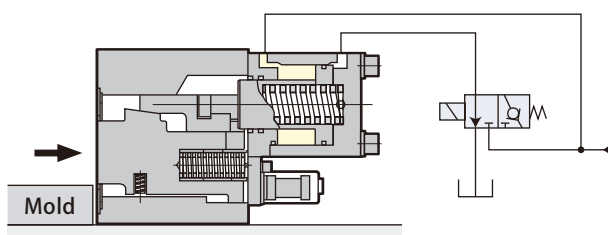

At time of unclamping, the lever is retracted back in the body and it does not interfere in loading/unloading the mold.

TKB & Positioning block

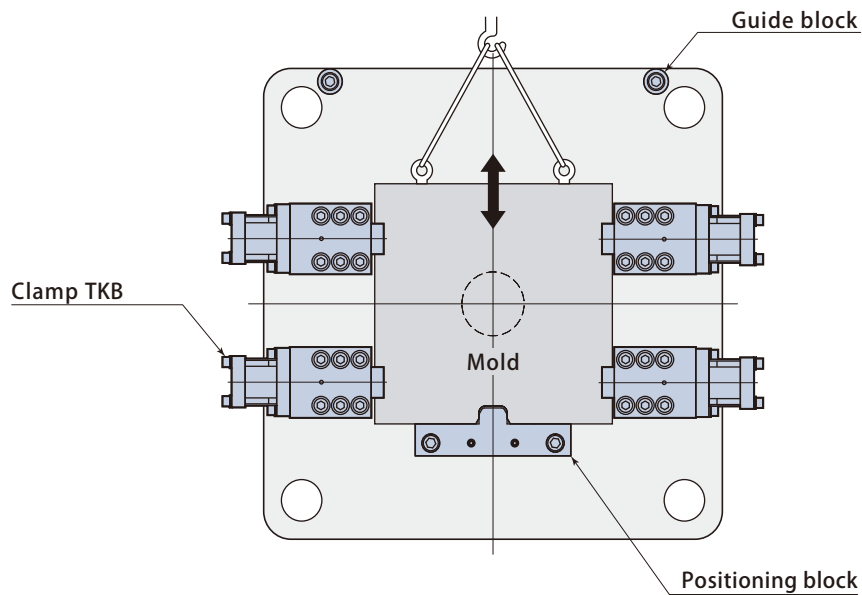

■ Model designation

TKB 160 — □

1 Holding force

4 Mold plate thickness
h dimension (mm) page → 50

■ Option

S Low distance clamp type

V Heat proof type

1 Specifications

Model			TKB160	TKB250	TKB400	TKB500
Holding force	At hydraulic pressure 13.7MPa	kN	156	245	392	490
	At no hydraulic pressure (0MPa)	kN	19.6	29.4	49	88.2
Clamping force	At hydraulic pressure 13.7MPa	kN	49	78.4	137.2	176.5
Full stroke		mm	4.5	4.5	5.5	5.5
Clamping stroke		mm	2	2	2.5	2.5
Safety stroke		mm	2.5	2.5	3	3
Cylinder capacity	Clamp	cm ³	284	460	859	859
	Unclamp	cm ³	173	277	507	507
Proof pressure		MPa	20.5			
At working hydraulic pressure		MPa	13.7			
Operating temperature		°C	0 ~ 80			
Weight		kg	38	67	130	160

● Refer to page → 67 for the details of cutout dimensions on mold.

Dimensions

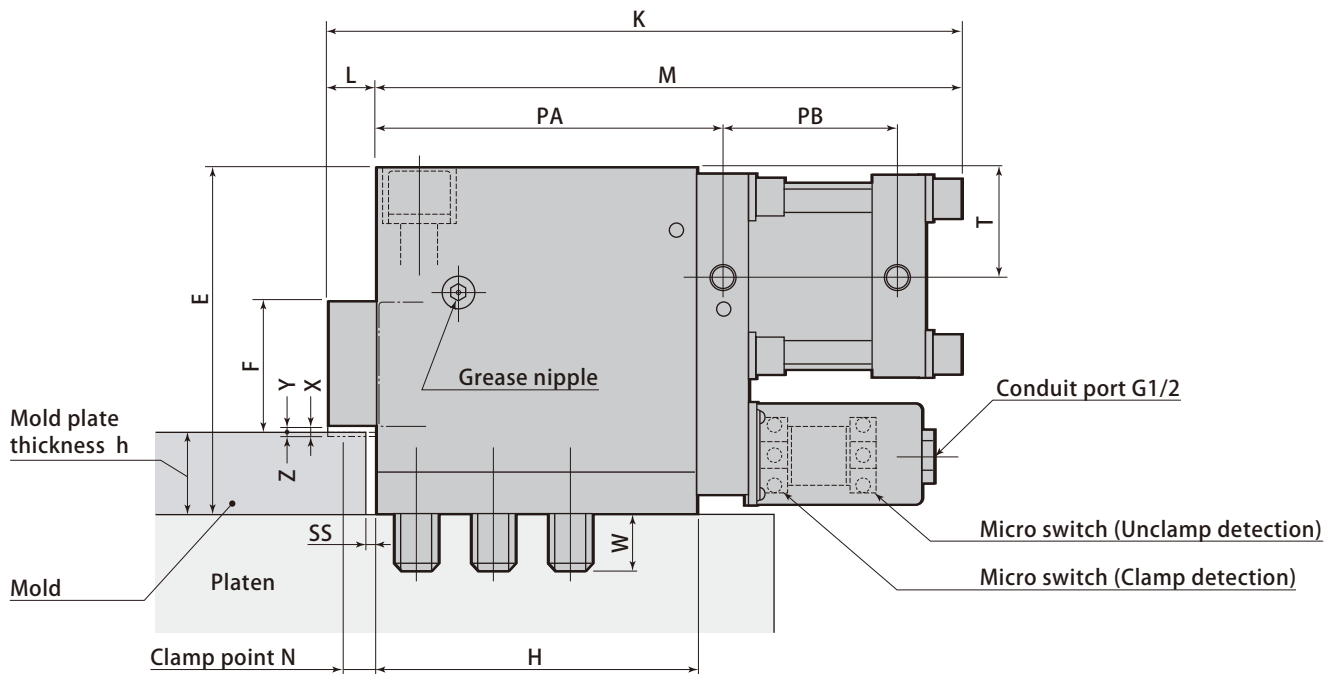
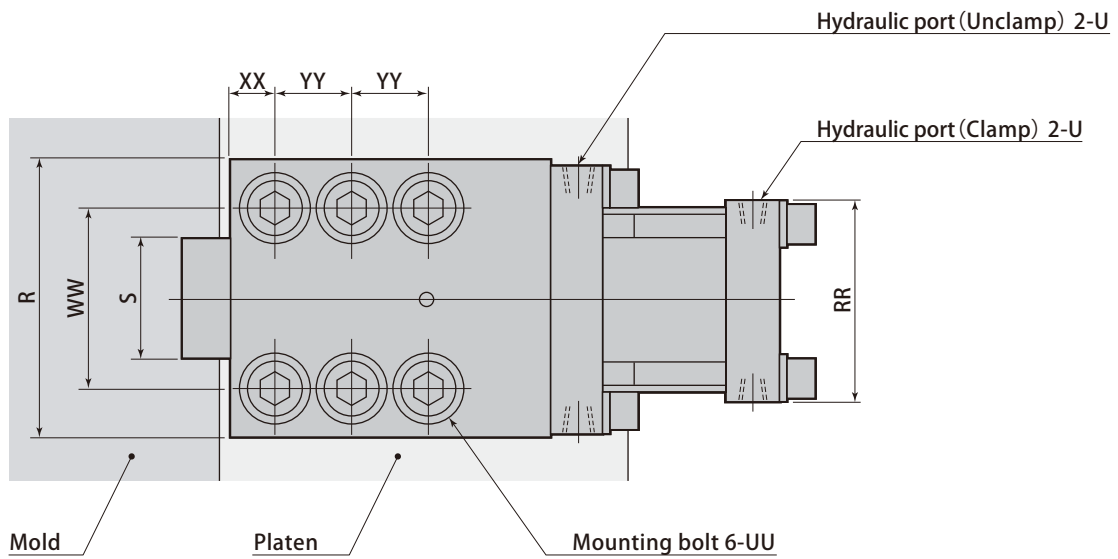

mm				
Model	TKB160	TKB250	TKB400	TKB500 (Standard)
Min. E	180	220	250	260
Height of lever F	75	82	99	99
H	165.5	204.5	242.5	292.5
K	342.9	401.2	472.1	522.1
L	32.9	32.7	38	38
M	310	368.5	434.1	484.1
N	20	20	25	25
PA	180.5	221	262	312
PB	99	110.5	129	129
R	145	175	215	215
RR	105	128	155	155
S	65	76	90	90
SS	3	3	5	5
T	58	69	81	91
Hydraulic port U	Rc3/8	Rc3/8	Rc3/8	Rc3/8
UU	M20	M24	M30	M30
W	31.4	35.6	52	52
WW	98	118	145	145
XX	22	27	32	32
YY	39	49	60	60
Full stroke X	4.5	4.5	5.5	5.5
Clamping stroke Y	2	2	2.5	2.5
Safety stroke Z	2.5	2.5	3	3
4 Min. h	40	50	50	50

Micro switch specifications (OMRON)

Micro switch model	Z-15 GD-B	
Rated voltage	V	AC250 DC30
Rated current (Resistance load)	A	15 6

T-slot, Cutout details and Clamp area details

- Process with the below dimension in case of machining T-slot newly.

Recommended T-slot dimension

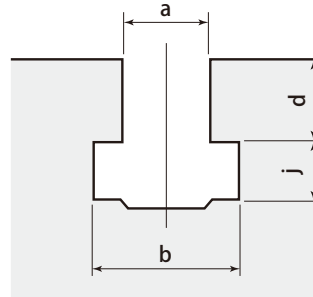

IMM	Mold clamping force	kN	~500	~1000	~1500	~2000	~3500	~5500	~6500	~8500	~13000	~30000	~35000
	Mold opening force	kN	40	80	100	160	250	400	640(400)	640	1000	1600	2000
T-slot dimension	a	mm	18 ^{+0.5} ₀		22 ^{+0.5} ₀		28 ^{+0.5} ₀		32 ^{+0.5} ₀				—
	b	mm	30 ⁺² ₀		37 ⁺³ ₀		46 ⁺⁴ ₀		53 ⁺⁴ ₀				—
	d	mm	18 ^{±0.2}		22 ^{±0.2}		28 ^{±0.2}		28 ^{±0.2}				—
	j	mm	12 ⁺² ₀		16 ⁺² ₀		20 ⁺² ₀		24 ⁺² ₀				—

- Mold plate should be machined referring to the dimensions shown below in case the mold is positioned by the block.

Cutout details

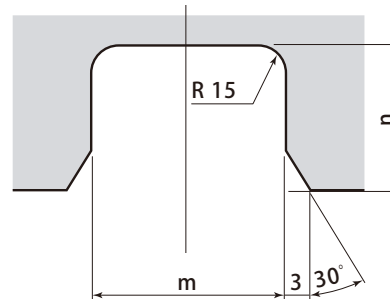

IMM	Mold clamping force	kN	~500	~1000	~1500	~2000	~3500	~5500	~6500	~8500	~13000	~30000	~35000
	Mold opening force	kN	40	80	100	160	250	400	640(400)	640	1000	1600	2000
Cutout details	m	mm		30 ^{+0.10} ₀		45 ^{+0.10} ₀	60 ^{+0.12} ₀	100 ^{+0.14} ₀				140 ^{+0.16} ₀	
	n	mm		30		30	35	40				45	

- To accommodate the clamp to the die as shown on the right, Pascal can provide a special designed clamp lever with the clamp. Contact Pascal for the details.

Clamp area details

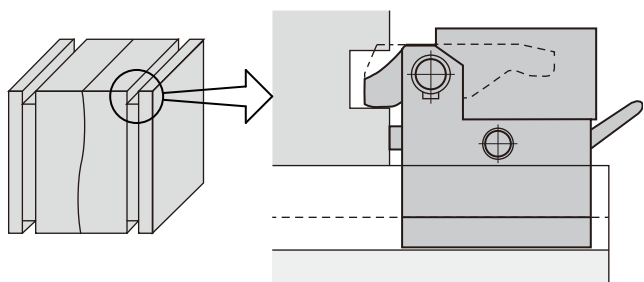

Unification of thickness of mold plate

The introduction of hydraulic and air clamp requires unification of thickness of mold plate.

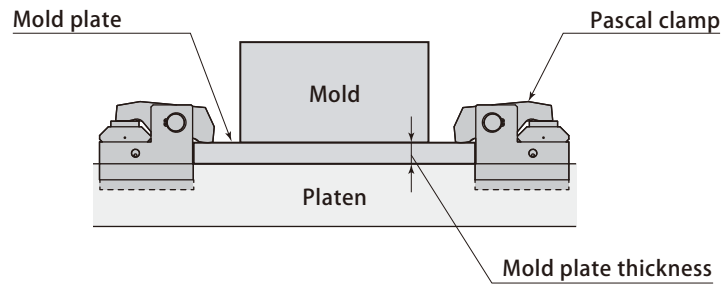

In case that the thickness of mold plate is not unified,
standardize **the maximum thick dimension h** and add the **spacer** at the clamp point.

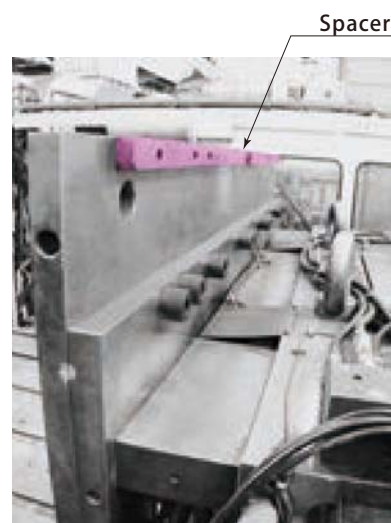
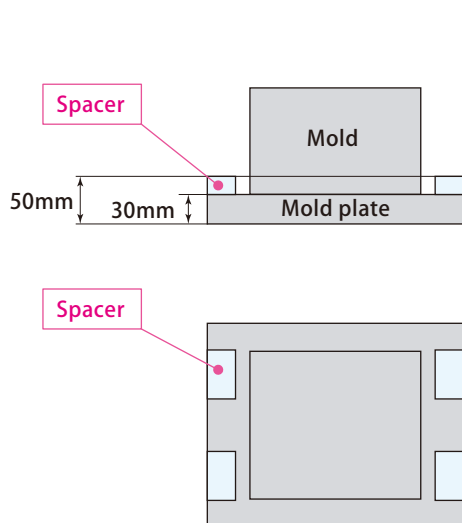
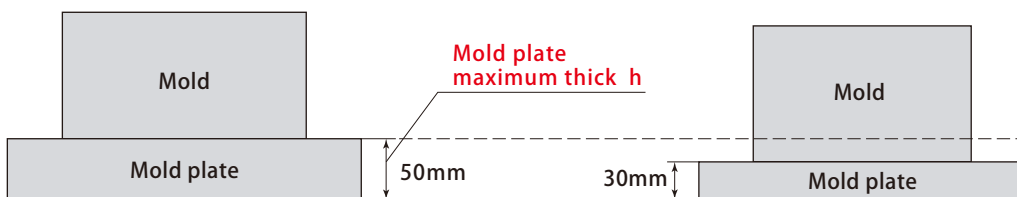

● Please contact for the details.

Addition of the hydraulic circuit

2 control circuits are recommended for clamp circuit on the movable platen.

The mold fall can be prevented with 2 control circuits, even if the pressure decreases in either one of 2 circuits.

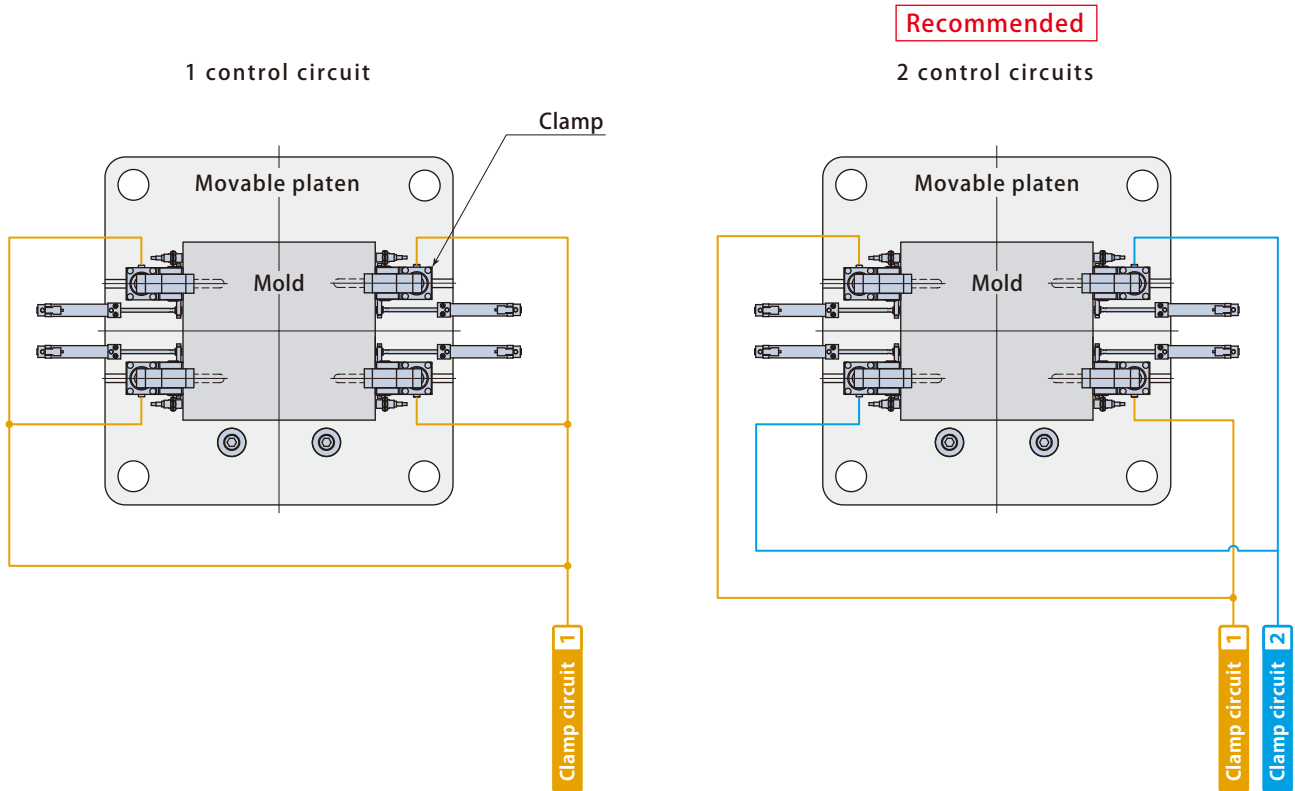

Use of the block for mold fall protection (Vertical loading)

Use of the block for mold fall protection is recommended on the movable side.

The mold fall to the underside can be prevented with the block, even if the pressure decreases and clamping force is loosened.

