

aerospace
climate control
electromechanical
filtration
fluid & gas handling
hydraulics
pneumatics
process control
sealing & shielding



AC30 Variable Speed Drive

AC30V, AC30P, and AC30D

For Open and Closed Loop Applications

1 - 350 HP (0.75 - 300 kW)



ENGINEERING YOUR SUCCESS.

 **WARNING - USER RESPONSIBILITY**

FAILURE OR IMPROPER SELECTION OR IMPROPER USE OF THE PRODUCTS DESCRIBED HEREIN OR RELATED ITEMS CAN CAUSE DEATH, PERSONAL INJURY AND PROPERTY DAMAGE.

This document and other information from Parker Hannifin Corporation, its subsidiaries and authorized distributors provide product or system options for further investigation by users having technical expertise.

The user, through its own analysis and testing, is solely responsible for making the final selection of the system and components and assuring that all performance, endurance, maintenance, safety and warning requirements of the application are met. The user must analyze all aspects of the application, follow applicable industry standards, and follow the information concerning the product in the current product catalog and in any other materials provided from Parker or its subsidiaries or authorized distributors.

To the extent that Parker or its subsidiaries or authorized distributors provide component or system options based upon data or specifications provided by the user, the user is responsible for determining that such data and specifications are suitable and sufficient for all applications and reasonably foreseeable uses of the components or systems.

OFFER OF SALE

The items described in this document are hereby offered for sale by Parker Hannifin Corporation, its subsidiaries or its authorized distributors. This offer and its acceptance by the provisions stated in the detailed 'Offer of Sale' which is available upon request.

AC30 - For Open and Closed Loop Control of Pump, Fan, and General Purpose Applications

Overview	5
Technical Specifications.....	12
Electrical Characteristics	12
Environmental Characteristics	13
Standards and Conformance	13
Dimensions	14
Connections	15
Accessories and Options	17
Operator Keypad	17
Data Storage and Cables	17
Mounting and Filter Kits	17
Communication Interfaces	18
Input and Output Cards.....	20
Ancillary Parts	22
Order Code.....	24
AC30 Variable Speed Drive, Accessories	24
Software	25
Parker Drive Quicktool (PDQ)	25
Related Products	26
Inverter and Vector Duty Induction Motors	26
NX Series PMAC Sensorless Motors	26

Parker Hannifin

The global leader in motion and control technologies and systems

Global Partnerships Global Support

Parker is committed to helping make our customers more productive and more profitable through our global offering of motion and control products and systems. In an increasingly competitive global economy, we seek to develop customer relationships as technology partnerships. Working closely with our customers, we can ensure the best selection of technologies to suit the needs of our customers' applications.

Electromechanical Technologies for High Dynamic Performance and Precision Motion

Parker electromechanical technologies form an important part of Parker's global motion and control offering. Electromechanical systems combine high performance speed and position control with the flexibility to adapt the systems to the rapidly changing needs of the industries we serve.



Drives Manufacturing

Parker drive products are manufactured globally to provide our customers with quality products at a competitive price point. In addition to factory-direct support, Parker provides sales assistance and local technical support through a group of dedicated sales teams and a network of authorized systems integrators, field service engineers, and technical distributors across the globe. For contact information, please refer to the Sales Offices listed on the back cover of this document or visit www.parker.com/ssdusa



Charlotte, NC



Littlehampton, UK



Wuxi, China



Chennai, India

Variable Speed Drive - AC30 Series

Overview

Description

AC30 drive has been designed to provide users with exceptional levels of control, from simple open-loop pumps and fans through to closed-loop process line applications. Its flexible and highly modular construction enables a wide range of communications and I/O modules to be easily added as required.

The AC30 has been designed with simplicity in mind, but this doesn't compromise its functionality. Integrated macros for a range of applications and PLC functionality enable more capable users to create sophisticated control that would previously have required a separate PLC.

Designed for operation in environment class 3C3 and 3C4 for Hydrogen Sulphide (H₂S) as standard (tested at 25 ppm for 1200 hours), temperatures up to 50 °C with optional integrated EMC filter to C2 1st environment and DC link choke to reduce line harmonics. AC30 also complies with RoHS substance restrictions in accordance with EC Directive 2011/65/EU. Units through 100 HP are marine certified by DNV-GL.

Features

Flexibility

- Open-loop or optional closed-loop operation with pulse encoder feedback module
- Suitable for operation with AC induction and Permanent Magnet AC (PMAC) servo motors
- Ethernet TCP/IP as standard
- I/O expansion options
- Support for popular industrial fieldbuses
- Chassis or through-panel mount as standard

Simplicity

- Parker DSE Lite or Parker Drive Quicktool (PDQ) drive management software tool
- Multi-language graphical keypad
- Quick start wizards
- Terminal covers removable with drive in place

Reliability

- Conformally coated for harsh environment protection as standard
- Marine application certified (through 100 HP)
- Isolated power stack cooling with removable fan



Technical Specifications - Overview

Ratings									
380-480 VAC Supply (±10%) Three Phase									
Normal Duty (Variable Torque)				Heavy Duty (Constant Torque)					
HP	kW	Output Current [A _{rms}]		HP	kW	Output Current [A _{rms}]		Frame	
		400 V	480 V			400 V	480 V		
1.5	1.1	3.5	3.0	1	0.75	2.5	2.1	D	
2	1.5	4.5	3.4	1.5	1.1	3.5	3.0	D	
3	2.2	5.5	4.8	2	1.5	4.5	3.4	D	
4	3	7.5	5.8	3	2.2	5.5	4.8	D	
5	4	10	7.6	4	3	7.5	5.8	D	
7.5	5.5	12	11	5	4	10	7.6	D	
10	7.5	16	14	7.5	5.5	12	11	E	
15	11	23	21	10	7.5	16	14	E	
20	15	32	27	15	11	23	21	F	
25	18.5	38	36	20	15	32	27	F	
30	22	45	40	25	18.5	38	36	G	
40	30	60	52	30	22	45	40	G	
50	37	73	65	40	30	60	52	G	
60	45	87	77	50	37	73	65	H	
75	55	105	96	60	45	87	77	H	
100	75	145	124	75	55	105	96	H	
125	90	180	156	100	75	145	124	J	
150	110	205	180	125	90	180	156	J	
200	132	260	240	150	110	205	180	J	
250	160	315	302	200	132	260	240	K	
300	200	380	361	250	160	315	302	K	
350	250	440	414	300	200	380	361	K	

Designed with you in mind

Throughout every stage of the design process, our engineering teams worked to equip the AC30 with a wealth of features that benefit both OEMs and End-users alike.

Working with the three principles of Flexibility, Simplicity and Reliability in mind, our engineers have created a product that not only delivers class-leading performance but also offers excellent usability in a host of motor control applications.

Flexibility

A fully featured list of standard functionality along with the use of common control and option modules allows users to put the drive to work in many different open or closed-loop applications without having to invest significant time and effort in re-engineering motor control systems.

Simplicity

From the clear and concise backlit LCD display to the power terminal covers that can be removed with the drive in the cabinet, AC30 has been engineered to make the process of operating and maintaining the drive as easy as possible.

Reliability

Although no one can guarantee problems will never happen, our engineers have taken every possible step to reduce their likelihood of occurring. We have included a number of features in the AC30 that will ensure any loss of productivity is minimized and production restarted as safely and as soon as possible.



Engineered cooling improves reliability

- Intelligent design minimizes force ventilation requirements
- Removable fan improves maintainability
- Isolated power stack cooling path reduces contamination of control electronics



Unobstructed access to power and dynamic brake terminals

- Terminal covers removable with drive in place
- Dynamic brake switch fitted as standard
- Easy access to DC Bus connections



Suitable for harsh environments

- AC30 is conformally coated as standard and meets the requirements of environment classes 3C1, 3C2 (all defined substances) plus 3C3 and 3C4 for Hydrogen Sulphide (H₂S)
- Internal EMC filter options up to C2 1st environment for use in commercial buildings
- CE marked to EN61800-5-1 and NRTL listed to UL508C and C22.2#14
- DC chokes above 3 HP reduce harmonics to below IEC/EN61000-3-12 limits
- Marine certified by GNV-DL through 100 HP



Compact footprint, chassis or through-panel mounting

- Multi-position feet with keyhole slots for ease of mounting
- Reduced heat radiation allows side-by-side mounting



Expandable I/O capabilities

- A range of option modules expand AC30 to accommodate application specific I/O
- High-performance, closed-loop control with pulse encoder feedback module
- Spring clamp terminals reduce installation time and risk of loose connections



Ethernet connectivity and built in diagnostic web pages

- Built in web pages allow AC30 to be interrogated over the onboard Ethernet and Modbus TCP/IP connection
- **LINKnet** compatible



Simplified configuration and data storage with SD cards

- SD card simplifies firmware updates and allows drive configuration and data to be stored



Intuitive and easy to use, multi-function graphical keypad

- Remote mountable and easy to use tactile keypad makes drive setup and operation simple



Safe-Torque-Off (STO) for safety critical applications

- Protecting users and machinery against unexpected motor start-up in accordance with EN13849-1 at PLe Cat3 or SIL 3 to EN61800-5-2

Field-installable communications

- Seamless integration into automation systems



Graphical Keypad

The tactile IP55 keypad can be mounted either on the drive itself or remotely and provides access to all drive functions.

The backlit LCD display can be configured to present information in any one of a number of different languages, or even in your own custom language with your own user-defined units.

Simple Setup Wizard and Macros

- Integrated quick start wizards means you don't have to be an expert to configure the drive within minutes
- Dedicated macros and integrated function blocks simplify the creation of specific motor control applications

Keypad Remote Mounting

The graphical keypad can be mounted remotely to the drive with the use of a connecting cable. When remote mounting, a blanking cover can be fitted to the drive in place of the keypad.

AC30 Series Variable Speed Drive

Overview

The AC30 is a modular product allowing users to select power stack, control module, I/O and communications modules and accessories to perfectly match the requirements of the application, making it a highly customizable yet cost effective solution. The three interchangeable control modules provide the basis for the series: the standard AC30V control module, the AC30P module with a host of advanced connectivity options, and the AC30D module which adds dual encoder and registration mark system capability.

1) Select Power Stack



Power stacks range from 1 to 350 HP.

2) Select Control Module



A range of control modules (V, P, or D) offer varying levels of intelligent automation control.

3) Select Comms & I/O Options



A wide range of communications, fieldbus, I/O and feedback options are available.

4) Choose accessories



Additional product accessories can be ordered to suit application and installation requirements.

AC30 Series Capability & Connectivity



AC30V

The AC30V is the base drive for **standalone applications**. More than a basic pump and fan drive, its program can be modified with easy to use Parker Drive Quicktool (PDQ) to match your exact requirements. The program can then be downloaded to an SD card. With full access from any network via its own IP address the drive can be integrated into any automation system via the top-mounted Ethernet port.



AC30P

Supporting latest developments in IoT and employing principles discussed in Industry 4.0 the AC30P is equipped with **Profinet, Ethernet/IP and Modbus TCP/IP via dual Ethernet ports**. This allows more advanced applications including multiple drive configurations. Plug into one port and access multiple drives supported by 1588 time synchronized peer to peer communication.



AC30D

The AC30D module gives you the great features of the AC30P as well as additional built in terminals to allow **dual encoder inputs and an encoder output**. This gives systems functionality to the AC30 allowing “electronic line shaft” capability, phase locking between drives, and registration control. This also frees up the I/O plug in slot to allow for even more I/O to be added if needed.

Feature	AC30V	AC30P	AC30D
Application Macros	Basic	System	System
Safety Torque Off (STO)	✓	✓	✓
Modbus Server	✓	✓	✓
Basic web server	✓	✓	✓
Parker Drive Quick (PDQ) tool programming	✓	✓	✓
DSE Developer software for legacy drive replacements	✓	✓	✓
Ethernet/IP	Option	✓	✓
Profinet	Option	✓	✓
Modbus client		✓	✓
System applications libraries		✓	✓
1588 time synchronized peer to peer comms		✓	✓
SMART diagnostics		✓	✓
User customizable web server		✓	✓
Parker Drive Developer (PDD) software (Codesys IEC61131)		✓	✓
Virtual master synchronization (same as AC890)		✓	✓
Multi-axis phase locking (same as AC690/890)		✓	✓
Dual encoder inputs			✓
Programmable encoder output			✓
2 high speed mark registration inputs			✓

System Design - Power

Versatile Power Configurations

The AC30 Series can be configured to operate in a number of different power configuration modes to suit the exact requirements of your application. The modularity of the AC30 Series enables different combinations of system components to be easily selected and installed to achieve the desired design, eliminating significant amounts of pre-engineering work.

Building Blocks

AC30 Series is based on a variety of basic system power components which can be combined to create a number of different input power configurations. All variants are available in power ratings through 350 HP.

Standard AC Inverter (710)

AC fed inverter suitable for use with a 380 - 480 VAC input. This can be used either as a standalone drive or as the AC input drive in a multi-drive application.



Active Front End (AFE)

The 710 power stack can operate in AFE control mode when used with the correct control module to provide a unity power factor, four-quadrant regenerative supply.



Line Regenerative Supply (380)

The Parker four-quadrant regenerative DC supply unit provides a low cost system power solution.



**Common DC Bus System
(supply from a single drive)**

Common DC bus system using a standard (710) inverter to supply the DC link. This design allows power sharing between drives, limiting the need for braking resistors in some cases. The power of the drives on the DC bus must not exceed double the power of the supply drive. In all common DC systems the braking between drives is synchronized allowing brake resistors to be added to one or more drives to best fit the requirements of the application.

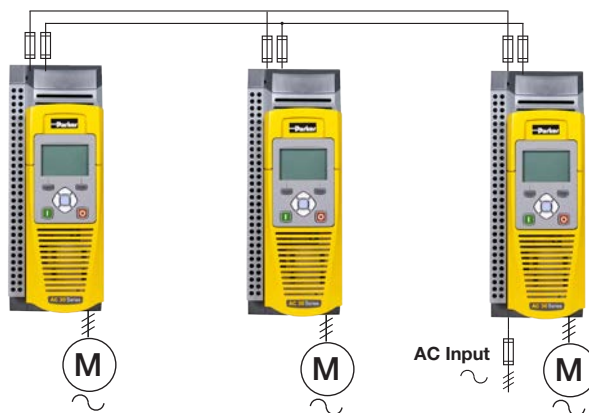

**Common DC Bus System
(supply to all drives)**

Common DC bus system using a standard (710) inverter with DC bus connection to all drives. This design allows power sharing between drives, limiting the need for braking resistors in some cases. Consideration is needed to include input chokes which can be required on each drive to balance the input currents between drives.

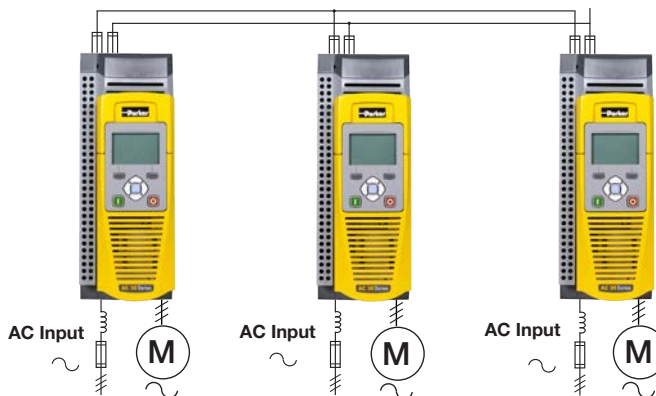

Common DC Bus System (Active Front End - AFE)

Common DC bus system using a 710 power stack and AC30P or D control modules to act as the AFE supply unit. The AFE must have the correct LCL filter to provide a pulse width modulated (PWM) controlled IGBT converter solution to allow bi-directional power flow to the AC line. The AFE is designed for applications with a high level of regeneration into the supply as no energy is wasted into braking resistors. The AFE solution also provides low harmonics, unity power factor and can provide voltage boost.

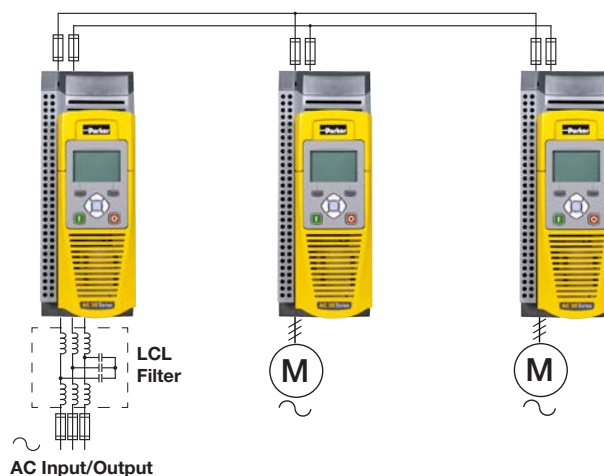

Common DC Bus System (regenerative supply)

Common DC bus system using a 380 line regen supply unit for cost sensitive applications where low harmonic performance is not required. The line regen unit is a compact and cost effective solution for DC supply to any AC30 drive system.

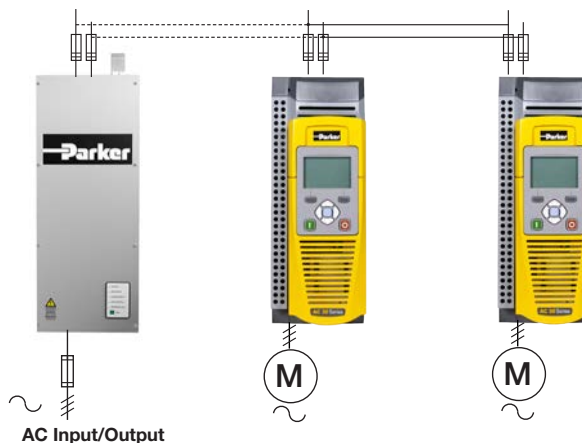

System Connectivity

The AC30 Series can be configured to operate in a number of different power control configuration modes to suit the exact requirements of your application. The flexibility of the AC30 Series enables our range of control modules to operate standalone or as an integral part of any automation architecture.

System Integration

The AC30 series can be easily integrated into your application supported by the wide range of connectivity options. AC30 series control modules can be programmed with our suite of software tools allowing users to configure the product to exactly match the application. Connectivity is provided via our hardware IO terminals offered on all control modules and expanded with our IO options or via standard and optional fieldbus modules.

Hardwired I/O Configuration

The AC30 series offers analog and digital inputs and outputs to maximize application compatibility. The I/O can be expanded using 7004 option modules.

Our standard application macros set each I/O point to a dedicated function. For customization the I/O can be configured to match your application using PDD or PDQ.



Fieldbus Configuration

Modbus TCP/IP is offered as standard on all AC30 control modules with Profinet and Ethernet/IP on the AC30P and AC30D. Parker offer a wide range of communications options for easy integration into any automation network.



Peer to Peer Configuration

The standard Ethernet on the AC30P/D offers peer to peer communication between drives. This allows for seamless data transfer. The peer to peer communication is 1588 time synchronized allowing phase locking between axis.



Parker Drive and HMI Network

The integrated PLC functionality inside the AC30 series allows applications to be programmed without a PLC. The IEC61131 flexibility and CODYSYS visualization deliver a low cost automation solution.

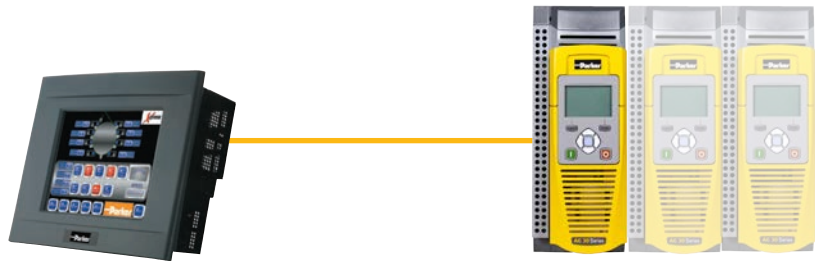

Parker Drive, PAC and HMI Network

For larger and more complex applications requiring a PLC, Parker can offer an intelligent cost-effective control solution. The AC30, PAC and PAC terminal can be programmed in a single software project.



Parker Drive and 3rd Party Ethernet PLC Network

The AC30 can be seamlessly integrated into a control architecture via LINKnet, Modbus TCP/IP, Profinet and Ethernet/IP without the need for any additional options. The flexibility of the AC30 software allows simple connectivity to a wide range of Ethernet master controllers.



Parker Drive and 3rd Party PLC Network

The range of AC30 fieldbus options allow simple connectivity and integration into a wide range of control architectures.



Simple and effective pump and fan control



Saving energy through speed control

Pumps and fans are widely used throughout industry. Some estimates suggest that a large proportion of these can be as much as 20% oversized for the application they are used in. When these are operated at a constant speed, a significant amount of the power consumed by the motor is wasted, costing your company considerable amounts of money and creating additional CO₂ emissions.

Matching the speed of pumps and fans to process demands with the AC30 ensures that the motor will always operate at the optimal speed to deliver just the right amount of air or fluid. This can result in significant energy savings. A 20% reduction in speed will actually reduce energy consumption by almost 50% and payback can be achieved in **less than 18 months in many cases.**

Speed control = Savings

- Up to 50% energy savings
- Improved power factor
- Reduced maintenance
- Quieter operation
- Increased service life
- Reduced carbon footprint

Improved power factor and service life

Pumps and fans that continuously operate at maximum speed inevitably have shorter life spans and are subject to unnecessary wear and tear. Variable speed drives can help improve service life while also reducing energy consumption and improving the power factor of your installations.

In addition to the cut in energy costs, you'll also see significant savings with maintenance and repair bills and a noticeable reduction in noise pollution as well.

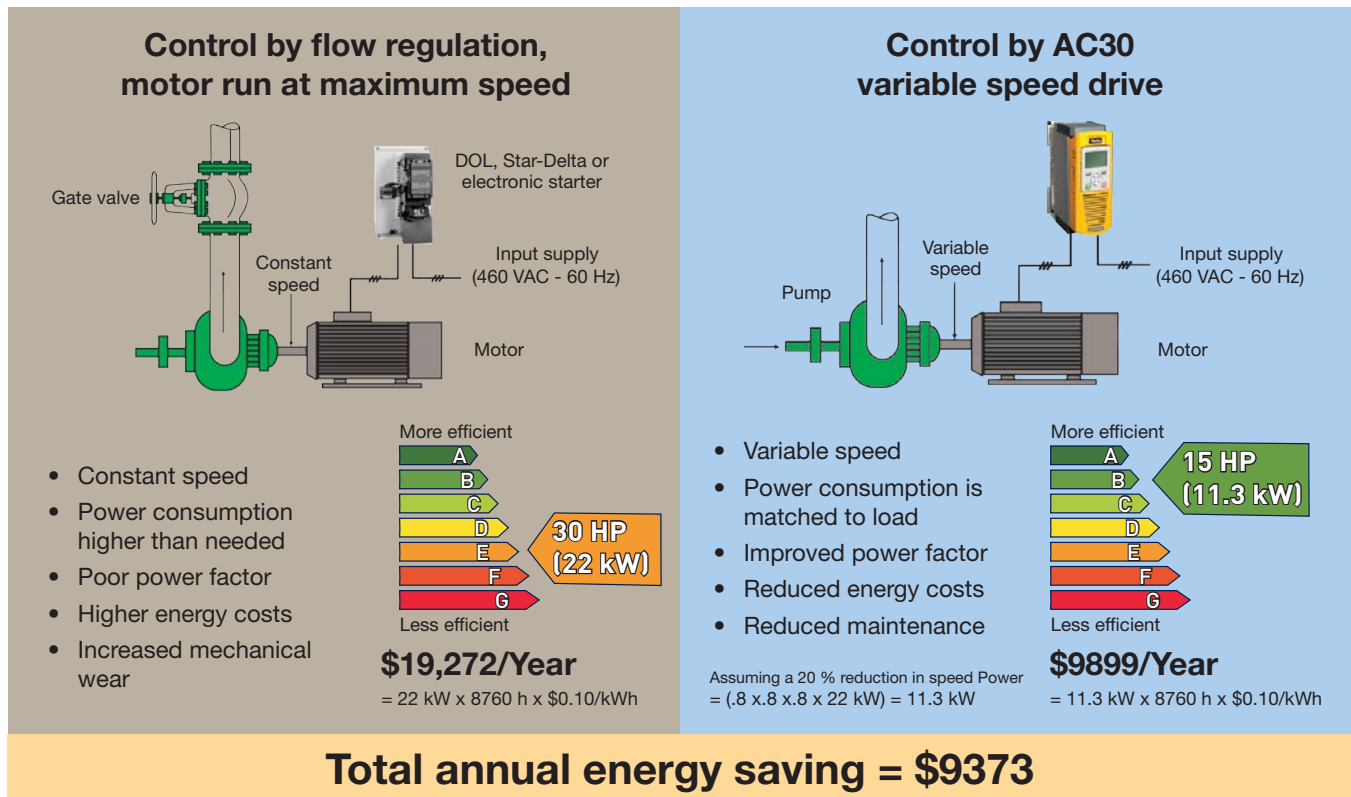

Designed to put you in control of your energy savings

AC30 is supplied complete with a number of features designed to simplify pump and fan control. In addition to quick setup, dedicated pump and fan macros, there are a number of other features dedicated to energy-saving pump and fan control such as:

Automatic belt breakage detection

Interactive monitoring of the running conditions of a fan allows AC30 to detect a breakage in the drive belt between the fan and motor, stop the motor and indicate an alarm condition.

Catching a spinning load - "fly-catching"

The fan control algorithms enable the AC30 to detect when a fan is free-wheeling and to regain control of it before running it at the commanded speed.

PID Control

Multiple PID control loops can be programmed to monitor process variables and adjust the speed of the motor accordingly to achieve the required variable setpoint.

Intelligent pump profiles

Our advanced intelligent pump control algorithms monitor motor loads and provides users with a number of features designed specifically for pump control applications, such as:

- Pump dry running protection
- Flow detection (low and no-flow)
- Blocked pump detection

Essential services (Fire mode)

Selected via digital input, Fire mode will cause the drive to run continuously at the maximum programmed speed ignoring all other control signals and alarm conditions.

Energy optimization

Under constant speed conditions, the motor power waveforms from the drive are optimized to reduce motor energy consumption without compromising performance.

Skip frequencies

Up to 4 speed and frequency bands can be programmed in the AC30, to enable resonant points on the fan to be avoided, reducing vibration, wear and noise.

Timed run function

With the optional Real Time Clock (RTC) module, 10 daily start/stop events can be programmed with different running speeds across a 7 day period. This function is ideally suited to applications where regular operating patterns or periods of activity need to be accommodated, such as in a production environment.

Process Timers

Multiple hours-run timers can be programmed to generate text alerts on the drive keypad to coincide with process maintenance intervals.



Engineered for any motor

In addition to the energy-saving associated with VFD control of pumps and fans. Additional energy saving can be achieved by using permanent magnet (PMAC) servo motors. AC30 offers effective and affordable control of either AC induction motors or PMAC motors.

PMAC motors are up to 10% more efficient and 75% smaller than standard AC induction motors

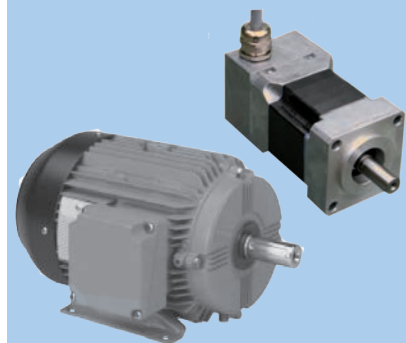

Closed-loop operation

An optional pulse encoder feedback module can be added to the AC30 for applications requiring more accurate speed or torque control of AC induction motors



Application Macros

Making use of pre-defined control logic, application macros enable users to quickly configure the AC30 for control of one of a number of pre-defined functions. Information is presented to the user in a template format which can then be simply and easily populated with the specific details of the application. This removes the complexity of designing the application logic from scratch.

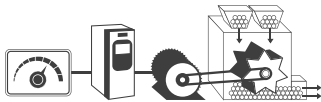

BASIC SPEED CONTROL

Set speed and voltage or current with start/stop direction control

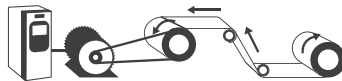

TORQUE CONTROL

Control the motor torque limit using an analog input

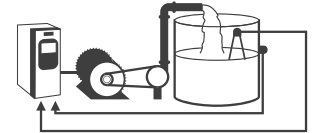

PUMP CONTROL

Dedicated pump control with specific pump functionality

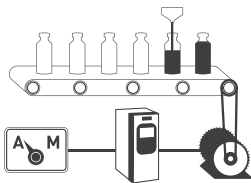

AUTOMATIC/MANUAL CONTROL

Set to run with local speed setting or external reference

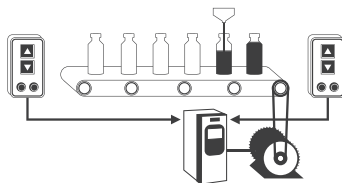

RAISE/LOWER

Increase or reduce speed using digital inputs

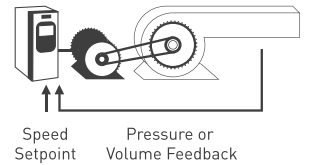

Speed Setpoint Pressure or Volume Feedback

PID CONTROL

Control the pressure, flow, temperature or any process variable

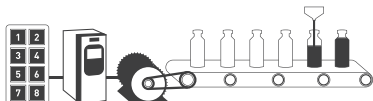

PRESET SPEED CONTROL

Select up to 8 pre-programmed speeds using digital inputs

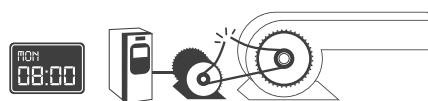

FAN CONTROL

Dedicated fan control with specific fan functionality

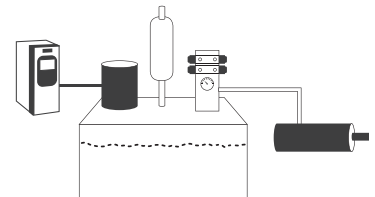

HYDRAULIC PUMP CONTROL

Efficient control of hydraulic pump applications, including accumulator charging, pressure control, flow control



Parker Drive Software

To enable communication between the AC30 drive and a PC, we offer two options: DSE Lite and Parker Quick Tool (PDQ) software. These programming, monitoring, and diagnostic software packages will get your newly installed AC30 drive up and running in no time!

Applications

With over 30 years experience of designing and building AC and DC drives and systems, Parker has a wealth of expertise in many different industries. The AC30 has been built on this experience and incorporates many flexible and innovative features, making it ideally suited for use in many industrial and commercial applications. Additional communications, expanded I/O and pulse encoder feedback option modules extend the capabilities of the AC30 still further, making it an extremely flexible and capable solution for all types of open- and closed-loop motor control requirements. Marine certification on units through 100 HP opens the door to shipboard and offshore applications.



Industrial Pump Control



Industrial Fan Control



Conveyor Control



Air Compressor Control

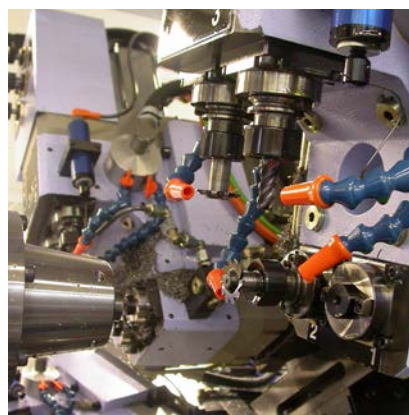

Machine Spindle



Hydraulic Pump Control

Technical Specifications

AC30 Power Stack Ratings

Power Stack Order Code	Normal Duty Ratings			Heavy Duty Ratings			Frame
	kW/HP	Output Current A _{rms}		kW/HP	Output Current A _{rms}		
		400 VAC	480 VAC		400 VAC	480 VAC	
380-480 (± 10 %) VAC Supplies Three Phase							
7x0-4D0004-B...	1.1/1.5	3.5	3.0	0.75/1	2.5	2.1	D
7x0-4D0005-B...	1.5/2	4.5	3.4	1.1/1.5	3.5	3.0	D
7x0-4D0006-B...	2.2/3	5.5	4.8	1.5/2	4.5	3.4	D
7x0-4D0008-B...	3/4	7.5	5.8	2.2/3	5.5	4.8	D
7x0-4D0010-B...	4/5	10	7.6	3/4	7.5	5.8	D
7x0-4D0012-B...	5.5/7.5	12	11	4/5	10	7.6	D
7x0-4E0016-B...	7.5/10	16	14	5.5/7.5	12	11	E
7x0-4E0023-B...	11/15	23	21	7.5/10	16	14	E
7x0-4F0032-B...	15/20	32	27	11/15	23	21	F
7x0-4F0038-B...	18/25	38	36	15/20	32	27	F
7x0-4G0045-B...	22/30	45	40	18/25	38	36	G
7x0-4G0060-B...	30/40	60	52	22/30	45	40	G
7x0-4G0073-B...	37/50	73	65	30/40	60	52	G
7x0-4H0087-B...	45/60	87	77	37/50	73	65	H
7x0-4H0105-B...	55/75	105	96	45/60	87	77	H
7x0-4H0145-B...	75/100	145	124	55/75	105	96	H
7x0-4J0180-B...	90/125	180	156	75/100	145	124	J
7x0-4J0205-B...	110/150	205	180	90/125	180	156	J
7x0-4J0260-B...	132/200	260	240	110/150	205	180	J
7x0-4K0300-B...	160/250	300	302	132/200	260	240	K
7x0-4K0380-B...	200/300	380	361	160/250	315	302	K
7x0-4K0440-B...	250/350	440	414	200/300	380	361	K

See Ordering Information for full order codes and description.

Electrical Characteristics

Power Supply	480 V Nominal
Rated Input Voltage	3 Ø 380-480 VAC ±10%
Input Frequency	45-65 Hz
Maximum Switching Frequency	4 kHz up to maximum of 12 kHz - de-rating may apply
Overload: Heavy Duty	150% for 60 seconds - 180% for 3 seconds
Overload: Normal Duty	110% for 60 seconds - 180% of HD full load current for 3 seconds
Output Frequencies	0-500 Hz at 4 kHz switching frequency 0-590 Hz at 8 kHz switching frequency 0-590 Hz at 12 kHz switching frequency
Earth Leakage Current	>10 mA (all models)

Technical Specifications

Environmental Characteristics

Operating Temperature	0 to +40°C (32°F to 104°F) Normal Duty, 0 to +45°C (32°F to 113°F) Heavy Duty, derate up to a maximum of +50°C (122°F) (Refer to manual for derating specifics)
Storage Temperature	-25°C to +55°C (-13°F to 131°F)
Shipping Temperature	-25°C to +70°C (-13°F to 158°F)
Product Enclosure Rating (Panel mounted) (Through-panel mounted)	IP20 - remainder of surfaces (Europe) UL (c-UL) Open Type (North America) IP20 UL (c-UL) Open Type (North America) IP20 UL (c-UL) Open Type (North America)
Altitude	1000 m ASL. Derate output by 1% per 100 m to a maximum of 2000 m
Operating Humidity	Maximum 85% relative humidity at 40°C (104°F) non-condensing
Atmosphere	Non-flammable, non-corrosive and dust free
Climatic Conditions	Class 3k3, as defined by EN60721-3-3
Chemically Active Substances	For the standard product, compliance with EN60271-3-3 is: <ul style="list-style-type: none"> • Both classes 3C3 and 3C4 for Hydrogen Sulphide gas (H₂S) at a concentration of 25 ppm for 1200 hours • Both classes 3C1 (rural) and 3C2 (urban) for all 9 defined substances as defined in table 4
Operating Vibration	Test Fc of EN60068-2-6 10 Hz<=f<=57 Hz sinusoidal 0.075 mm amplitude 57 Hz<=f<=150 Hz sinusoidal 1 g 10 sweep cycles per axis on each of three mutually perpendicular axes
Overvoltage Category	Overvoltage category III (numeral defining an impulse withstand level)
Pollution Degree	Pollution degree II (non-conductive pollution, except for temporary condensation) for control electronics Pollution Degree III (dirty air rating) for through-panel mounted parts

Standards and Conformance

North America/Canada	Complies with the requirements of UL508C and CSA22.2 #14 as an open-type drive
Europe	This product conforms with the Low Voltage Directive 2006/95/EC
EMC Compatibility	CE Marked in accordance with 2004/108/EC (EMC Directive)
RoHS Compliance	This product complies with RoHS substance restrictions in accordance with EC Directive 2011/65/EU
Reach	This product complies with the REACH regulations EC1907/2006
European Machinery Directive	Safe-Torque-Off (STO) complies with the requirements of ISO13849-1 (Safety-related parts of control systems) at PLe Cat3 or SIL 3 to EN61800-5-2
DNV Marine Certification (Det Norske Veritas)	Complies with the 'Classification of Ships, High Speed & Light Craft and Det Norske Veritas Offshore Standards'. This applies to all AC30 Frequency converters with powers up to 100 HP for use in marine and offshore applications

Dimensions

Panel Mounting

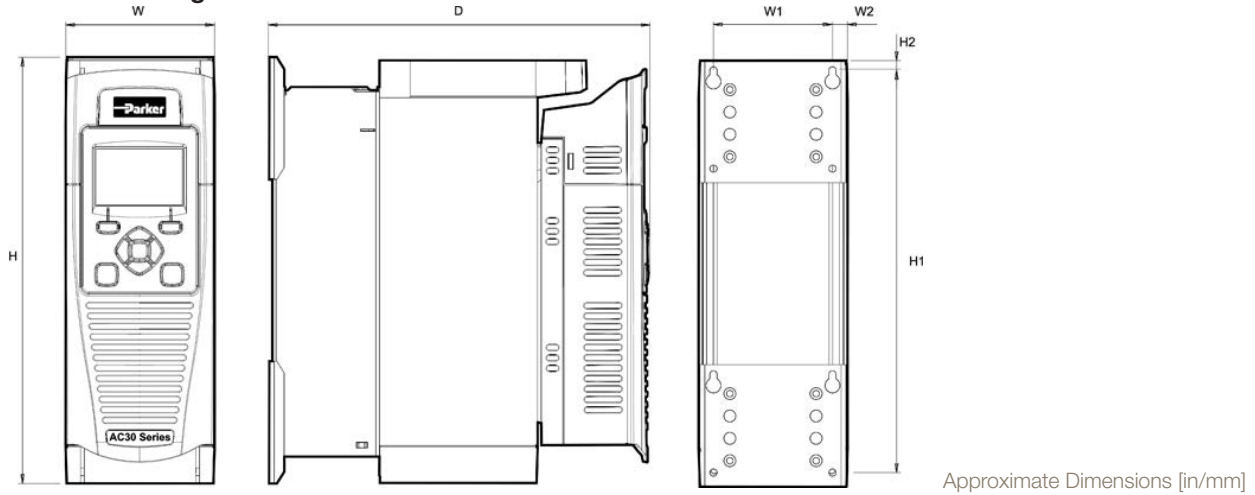

Size	Max. Weight [lb/kg]	H	H1	H2	W	W1	W2	D	Mounting
Frame D	10/4.5	11.26/286.0	10.6/270.0	0.25/6.5	3.93/100.0	3.15/80.0	0.39/10.0	10.0/255.0	4.5mm slot, M4 mountings
Frame E	15/6.8	13.11/333.0	12.6/320.0	0.25/6.5	4.92/125.0	3.93/100.0	0.49/12.5	10.0/255.0	
Frame F	22/10.0	15.07/383.0	14.5/370.0	0.25/6.5	5.90/150.0	4.92/125.0	0.49/12.5	10.0/255.0	
Frame G	49/22.3	18.90/480.0	18.31/465.0	0.29/7.25	8.66/220.0	7.48/190	0.51/13.0	11.30/287	5.5mm slot, M5
Frame H	95/42.8	26.38/670.0	25.59/650.0	0.39/10.0	10.24/260.0	8.66/220	0.79/20	12.44/316	6.8mm slot, M6
Frame J	196/89	31.5/800	30.7/780	0.39/10.0	13/330	11.22/285	0.89/22.5	14.72/374	M8 mountings
Frame K	276/125	51.2/1300	50/1272	0.55/14.0	15.75/400	11/280	2.36/60	15.16/385	M10 mountings

Through-Panel Mounting

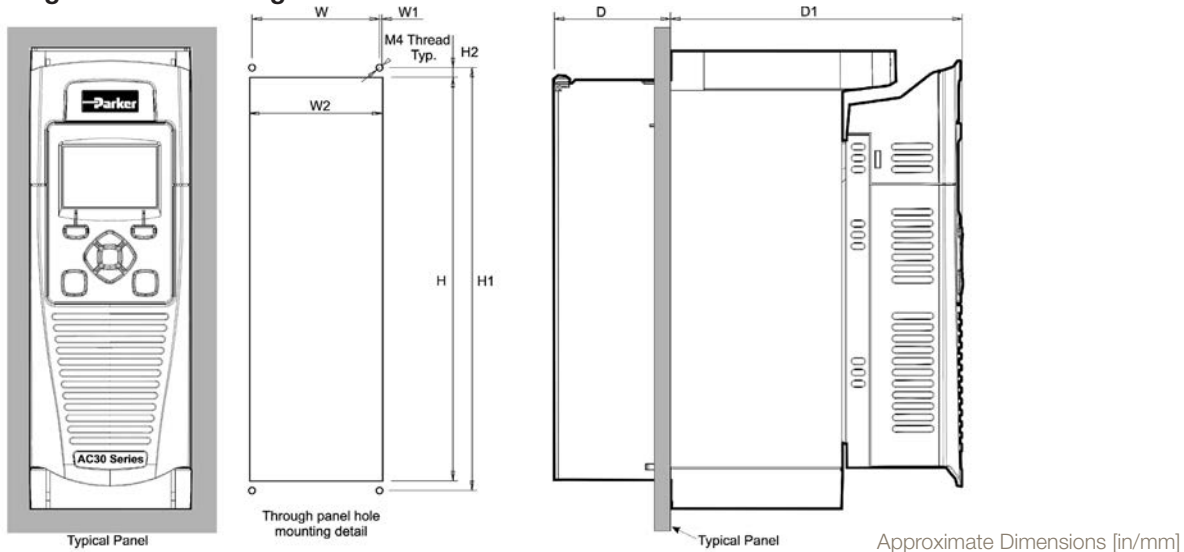

Size	H	H1	H2	W	W1	W2	D	D1	Mounting
Frame D	9.8/250	10.3/262	0.24/6	3.1/79	0.06/1.5	3.2/82	2.8/72	7.1/181	Use M4 mountings
Frame E	11.7/297	12.2/309	0.24/6	4.1/104	0.04/1	4.0/102	2.8/72	7.1/181	
Frame F	13.7/347	14.1/359	0.24/6	5.1/129	0.04/1	5.0/127	2.8/72	7.1/181	
Frame G	17.3/440	17.9/455.8	0.31/7.9	7.7/195	0.02/0.4	7.7/195.8	3.74/95	7.5/190	Use M5 mountings
Frame H	24.3/617	25.2/641	0.47/12	8.6/218	4.5	8.9/227	3.9/99	8.3/211	Use M6 mountings
Frame J	29.3/745	765	0.39/10	10.8/275	12.5	11.8/300	5.0/128	9.55/242.6	Use M6 mountings

Connections

Power connections

Term.	Description
DB+	Dynamic Brake Resistor
DB-	Dynamic Brake Resistor
DC+	DC Link Bus +
DC-	DC Link Bus -
L1	L1 AC Input Supply
L2	L2 AC Input Supply
L3	L3 AC input Supply
M1	Motor Output 1/U
M2	Motor Output 2/V
M3	Motor Output 3/W

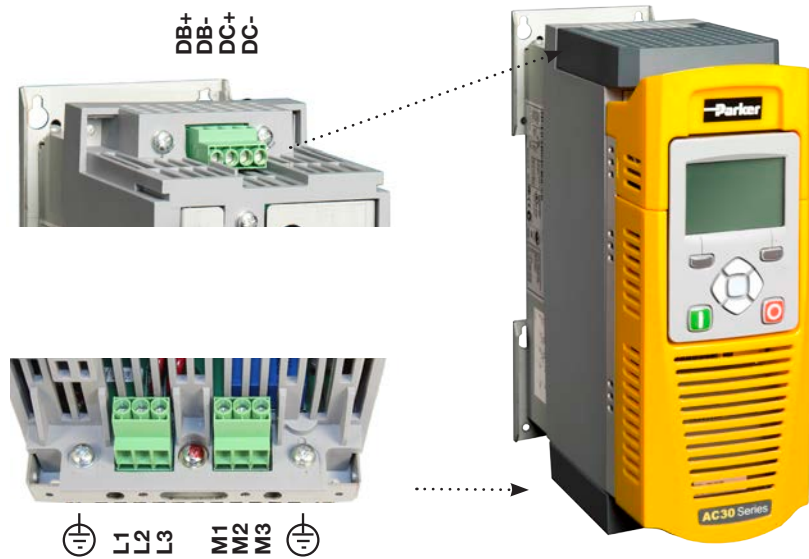

Safe Torque Off (STO)

The AC30 series features Safe Torque Off functionality as standard, offering users protection against unexpected motor start-up in accordance with EN13849-1 at PLe Cat 3 or SIL 3 to EN61800-5-2.

The STO functionality helps protect personnel and machinery by preventing the drive from restarting automatically. It disables the drive pulses and inhibits the power supply to the motor, so that the drive cannot generate any potentially hazardous movement. The state is monitored internally within the drive.

The example wiring diagram shows the minimum connections required to implement STO with the AC30 series AC drives.

Term.	Label	Description
X10/01	STO A Input	STO Channel A input signal
X10/02	STO Common	Return signals for STO A and STO B
X10/03	STO B Input	STO Channel B input signal
X10/04	STO Common	Return signals for STO A and STO B
X10/05	STATUS A	STO Status Indication
X10/06	STATUS B	STO Status Indication

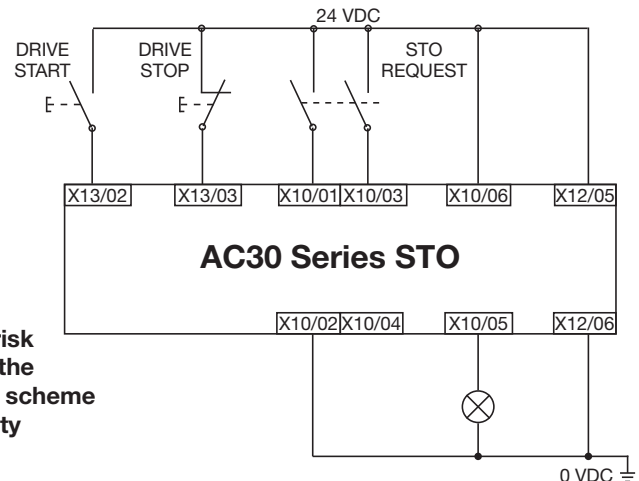

Users must conduct a risk assessment to identify the appropriate STO wiring scheme and ensure that all safety requirements are met.



It is the user's responsibility to ensure the safe and correct use of the STO function of the AC30 Series. Users should read and fully understand chapter 6 (Safe Torque Off) of the product user manual. Manual No. HA501718U001

Control wiring connections: AC30V & AC30P

Term.	Label
X10/01	STO A Input
X10/02	STO Common Return
X10/03	STO B Input
X10/04	STO Common Return
X10/05	STO Status A
X10/06	STO Status B
X11/01	ANIN 01 Analog Input (± 10 V, 0-10 V, 0-20 mA, 4-20 mA)
X11/02	ANIN 02 Analog Input (± 10 V, 0-10 V)
X11/03	ANOUT 01 Analog output (± 10 V, 0-10 V)
X11/04	ANOUT 02 Analog output (0-10 V, 0-20 mA, 4-20 mA)
X11/05	+10 V Reference
X11/06	-10 V Reference
X12/01	DIGIN04 / DIGOUT 01 Digital In/Out
X12/02	DIGIN05 / DIGOUT 02 Digital In/Out
X12/03	DIGIN06 / DIGOUT 03 Digital In/Out
X12/04	DIGIN07 / DIGOUT 04 Digital In/Out
X12/05	User +24 V Output
X12/06	0 V Common

Term.	Label
X13/01	0V Common
X13/02	DIGIN 1 Digital Input
X13/03	DIGIN 2 Digital Input
X13/04	DIGIN 3 Digital Input
X13/05	+24 V Auxiliary Input
X13/06	0 V Auxiliary Input
X14/01	Relay Output 01 (Contact A)
X14/02	Relay Output 01 (Contact B)
X14/03	Relay Output 02 (Contact A)
X14/04	Relay Output 02 (Contact B)

*Relay outputs are not present on AC30P/D. These are replaced by dual Ethernet ports.

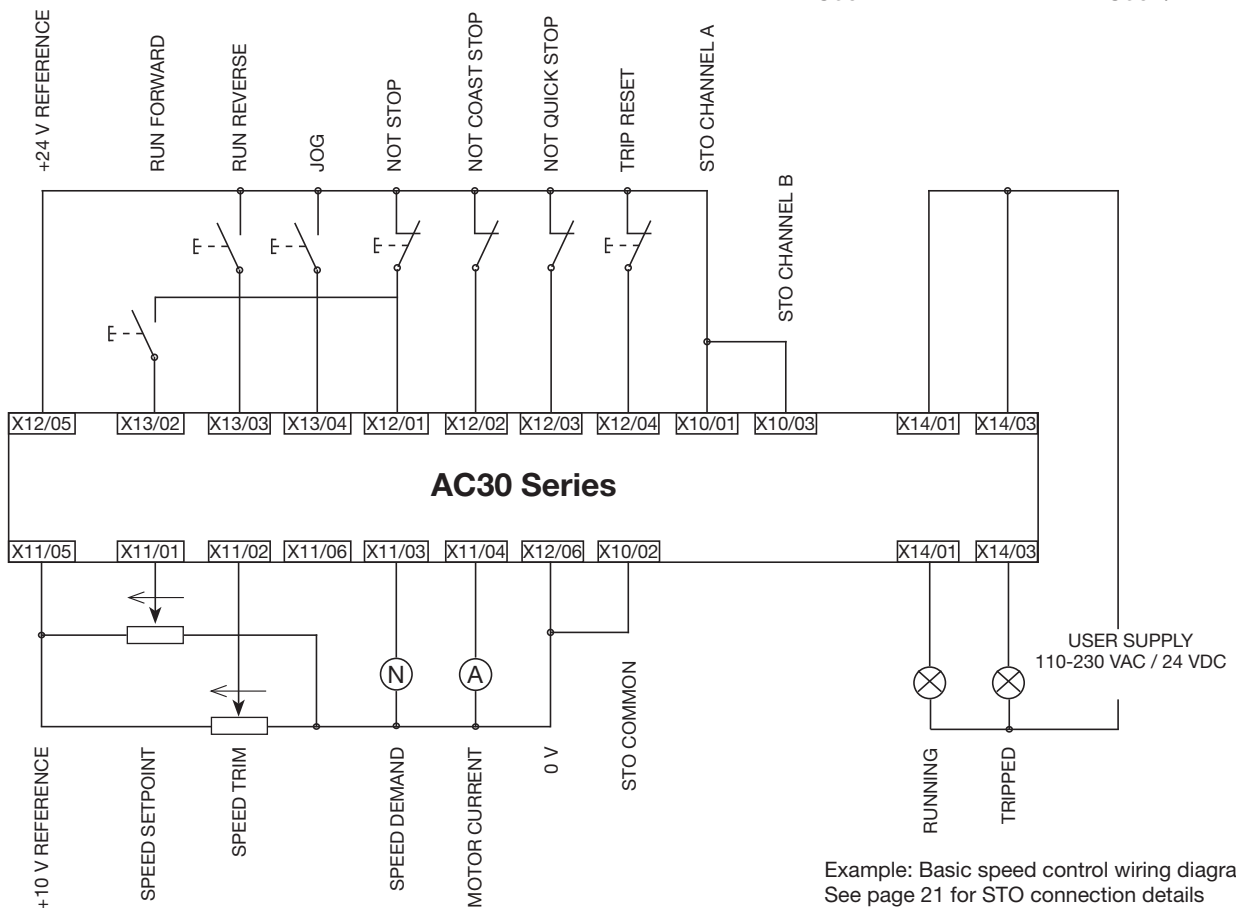
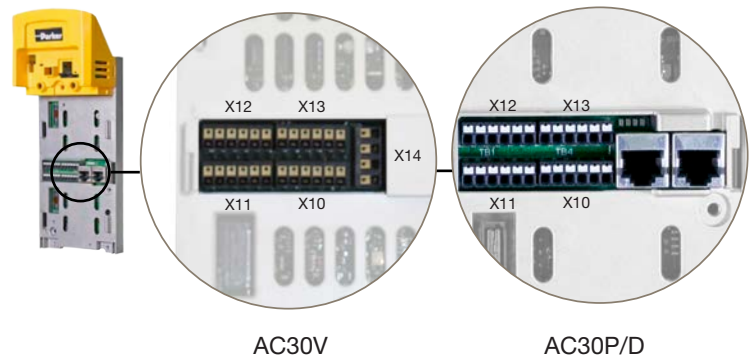

Example: Basic speed control wiring diagram
 See page 21 for STO connection details

Control wiring connections: AC30D

The wiring on the AC30D is the same as AC30P with the additional systems connections shown below.

Term.	Label
X30/01	DIGIN 1
X30/02	DIGIN 2
X30/03	DIGIN 3
X30/04	DIGIN 0V
X30/05	+24V System Aux. Input
X30/06	0V System Aux. Input
X31/01	Encoder 2 - A Input
X31/02	Encoder 2 - /A Input
X31/03	Encoder 2 - B Input
X31/04	Encoder 2 - /B Input
X31/05	Encoder 2 - Z Input
X31/06	Encoder 2 - /Z Input
X31/07	Encoder PSU Output - Positive Terminal (internally connected to X32/07)
X31/08	Encoder PSU Output - 0V Terminal (internally connected to X32/08)

Term.	Label
X32/01	Encoder 1 - A Input
X32/02	Encoder 1 - /A Input
X32/03	Encoder 1 - B Input
X32/04	Encoder 1 - /B Input
X32/05	Encoder 1 - Z Input
X32/06	Encoder 1 - /Z Input
X32/07	Encoder PSU Output - Positive Terminal (internally connected to X31/07)
X32/08	Encoder PSU Output - 0V Terminal (internally connected to X31/08)
X33/01	Encoder Transmit - A Output
X33/02	Encoder Transmit - /A Output
X33/03	Encoder Transmit - B Output
X33/04	Encoder Transmit - /B Output
X33/05	Encoder Transmit - Z Output
X33/06	Encoder Transmit - /Z Output

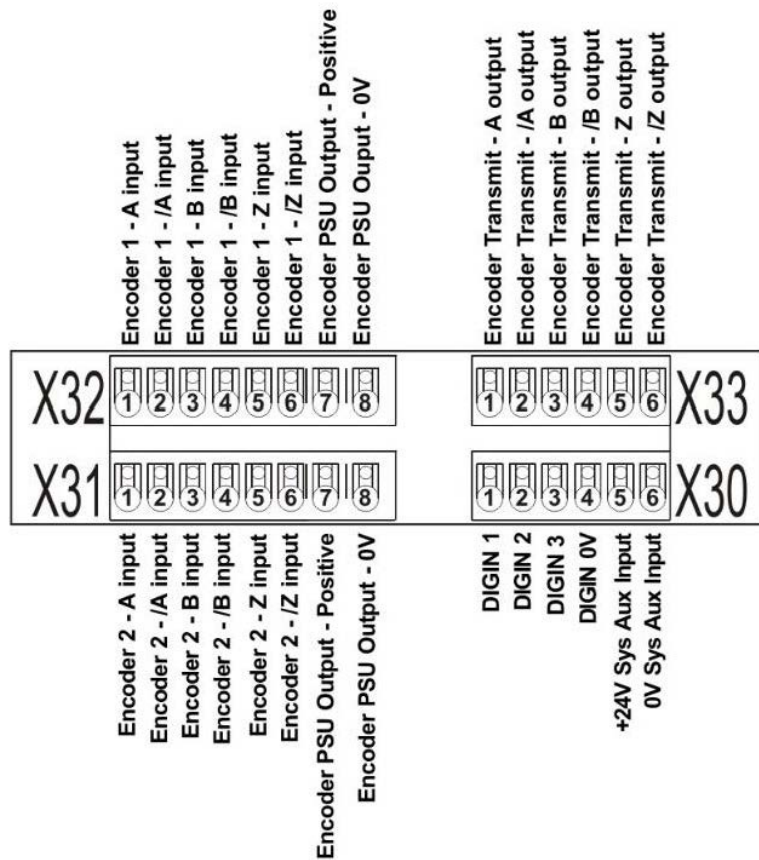
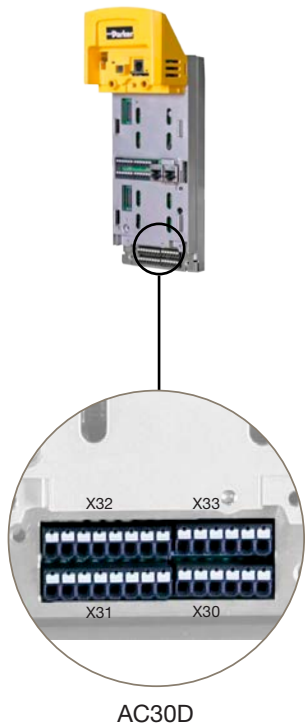

Parker Drive Line Regeneration Unit

The Parker Drive Line Regeneration unit enables full energy flow in both directions. Line Modules centrally feed the energy into the DC link. Line Modules with regulated infeed/regenerative feedback can optionally ensure a constant DC link voltage and a high degree of compatibility with the line supply.

Advantages

- Compact size
- Braking energy of drive systems is regenerated into the network
- No input power connection for each of the AC30 drives is required!
- Power can be perfectly adapted to the application
- Network frequency 40-60Hz
- DC intermediate circuit coupling of several drive controllers possible
- Low-loss and high-quality IGBT power unit
- Self-synchronizing
- Reliability: electronic overload protection in feedback operation
- Monitoring of line voltage, phase rotation and temperature very high efficiency of > 99%/>98% (Drive/Regen mode) by effective real time controlling and analog operation principle
- Enables highly dynamic braking operations
- User-friendly start-up: no programming or parameter settings are required
- Significant reduction of heat loss by regenerative operation.
- Maintenance free power feedback unit due to the innovative concept
- Duty cycle = 100%



Technical Information

Order Code	Input Current - AC (A)		Input Current - DC (A)		Frame Size	Weight (lb/Kg)	Power Loss (W)
	Driving	Regenerating	Driving	Regenerating			
380-5R0094-NE-0000	74	60	94	69	R	97/44	750
380-5R0157-NE-0000	124	99	157	115	R	145/66	1265
380-5S0251-NE-0000	198	159	251	184	S	220/100	1900
380-5S0394-NE-0000	310	248	394	288	S	242/110	2852
380-5S0536-NE-0000	422	338	536	392	S	254/115	3500

Dimensions

Model	Height (in/mm)	Width (in/mm)	Depth (in/mm)
Frame R	29.7/754	10.1/256	12.6/320
Frame S	37.2/944	14.9/378	15.4/390

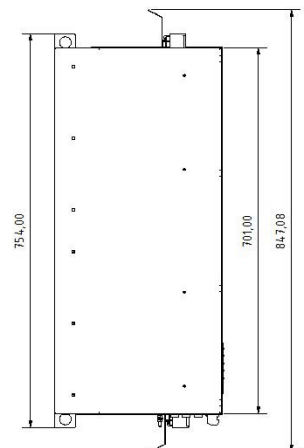
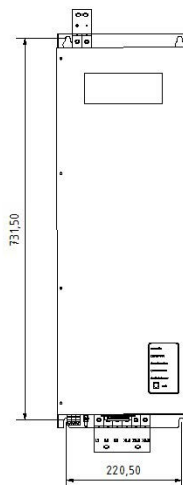
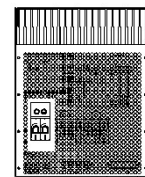
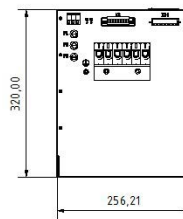

Accessories and Options

Operator Keypad

Order Code	Description
7001-00-00	IP54 Graphical keypad
7001-01-00	Keypad blanking cover
LA501991U300	Keypad remote mounting kit (3 m cable and screws)

Description:

The backlit LCD graphical keypad can be either mounted locally on the drive or remotely with the use of a remote mounting kit. The keypad has 3 pass code protected user access levels. The keypad can be used to set-up and commission the drive, change parameter settings, monitor running status or diagnose warning or alarm conditions. The display information can be shown in English, German, French, Spanish or Italian.



7001-00-00



7001-01-00

Data Storage and Cables

Order Code	Description
IF501990	SD card 2GB
CM501989U010	Ethernet cable 1 m
CM501989U011	Ethernet cable 3 m
CM501989U012	Ethernet cable 5 m



IF501990

Mounting and Filter Kits

Order Code	Description
BO501911U001	Frame D through panel mounting gasket
BO501911U002	Frame E through panel mounting gasket
BO501911U003	Frame F through panel mounting gasket
BO501911U004	Frame G through panel mounting gasket
BO501911U005	Frame H through panel mounting gasket
LA502793	Frame J through panel mounting gasket kit
LA501935U001	Frame D C2 environment filter kit
LA501935U002	Frame E C2 environment filter kit
LA501935U003	Frame F C2 environment filter kit
LA501935U004	Frame G C2 cable screening kit
LA501935U005	Frame H C2 cable screening kit
LA501935U006	Frame J cable screening kit



LA501935UU001

The environment filter kit consists of a motor cable ferrite core and screening brackets and is required to comply with the requirements of the EMC directive for a C2 environment with frames D, E and F. For frame G the drive has a different EMC internal filter which is required in addition to the screen kit. For frame H, an external EMC filter is required.

Communication Interfaces

7003-PB-00	PROFIBUS DP-V1 communication interface
Supported Protocols	PROFIBUS-DP; Demand data and Data exchange
Communication Speed	Up to 12 Mbits/s; automatically detected
Max. number of devices	32 per segment, 126 total
Supported Messages	Up to 152 bytes cyclic I/O, 68 bytes class 1 and 2 acyclic data, 152 bytes configuration data. GSD file provided



7003-DN-00	DeviceNet communication interface
Supported Protocols	DeviceNet protocol (slave)
Communication Speed	125, 250, 500 kbits/s or automatically detected
Max. number of devices	64
Supported Messages	Bit strobed I/O, Polled I/O, Cyclic I/O, Change of state, Explicit messaging



7003-CB-00	CANopen communication interface
Profile	DS301 V4.02
Communication Speed	10 k, 20 k, 50 k, 125 k, 250 k, 500 k, 1 Mbits/s or automatically detected
Max. number of devices	127
Supported Messages	SDO, PDO, NMT, SYNC



7003-PN-00	PROFINET I/O communication interface
Supported Protocols	PROFINET I/O Real-Time (RT) Protocol
Communication Speed	100 Mbits/s full duplex
Max. number of devices	Virtually unlimited
Supported Messages	Up to 256 bytes of cyclic I/O in data in each direction



7003-IP-00	Ethernet IP communication interface
Supported Protocols	Ethernet IP
Communication Speed	10/100 Mbits/s full/half duplex
Max. number of devices	Virtually unlimited
Supported Messages	Up to 256 bytes of consumed data and 256 bytes of produced data, CIP parameter object support, Explicit messaging



7003-RS-00	RS485 / Modbus RTU communication interface
Supported Protocols	Modbus RTU
Communication Speed	1200 to 115200 bits/s
Max. number of devices	247
Supported Messages	Up to 256 bytes of cyclic I/O data in each direction



Communication Interfaces

7003-BN-00	BACnet MSTP communication interface
Supported Protocols	BACnet/MSTP
Communication Speed	up to 76.8 kbits/s
Max. number of devices	255
Supported Messages	Real time synchronization according to DM-T S-B, COV notifications and Alarm/Event functionality



7003-BI-00	BACnet/IP communication interface
Supported Protocols	BACnet/IP
Communication Speed	100 Mbits/s
Max. number of devices	255
Supported Messages	Real time synchronization according to DM-T S-B, COV notifications and Alarm/Event functionality



7003-CN-00	ControlNet communication interface
Supported Protocols	ControlNet
Communication Speed	5 Mbits/s
Max. number of devices	99
Supported Messages	Polled I/O



7003-EC-00	EtherCAT communication interface
Supported Protocols	CANopen over EtherCAT (CoE) DS301 compliant
Communication Speed	100 Mbits/s
Max. number of devices	65534
Supported Messages	SDO, PDO, NMT, SYNC



7003-IM-00	Ethernet TCP communication interface
Supported Protocols	Modbus/TCP
Communication Speed	10/100 Mbits/s
Max. number of devices	Virtually unlimited
Supported Messages	CIP parameter object support, explicit messaging



Input and Output Cards

7004-01-00 - General Purpose I/O Module

Digital Inputs & Outputs	4x Digital inputs or outputs
Analog Inputs/Outputs	3x Analog inputs (± 10 V)
Relay Outputs	2x Volt-free relay outputs (230 VAC)
Motor Temperature Sensing	1 motor thermistor input
Real time Clock	Included

Description:

The general purpose I/O (GPIO) option module can be fitted to all AC30 series drives in the upper I/O option module slot. The modules are field installable and offer users the opportunity to expand the drive's standard I/O capability, allowing more complex motor control solutions to be implemented.

Connection Details:

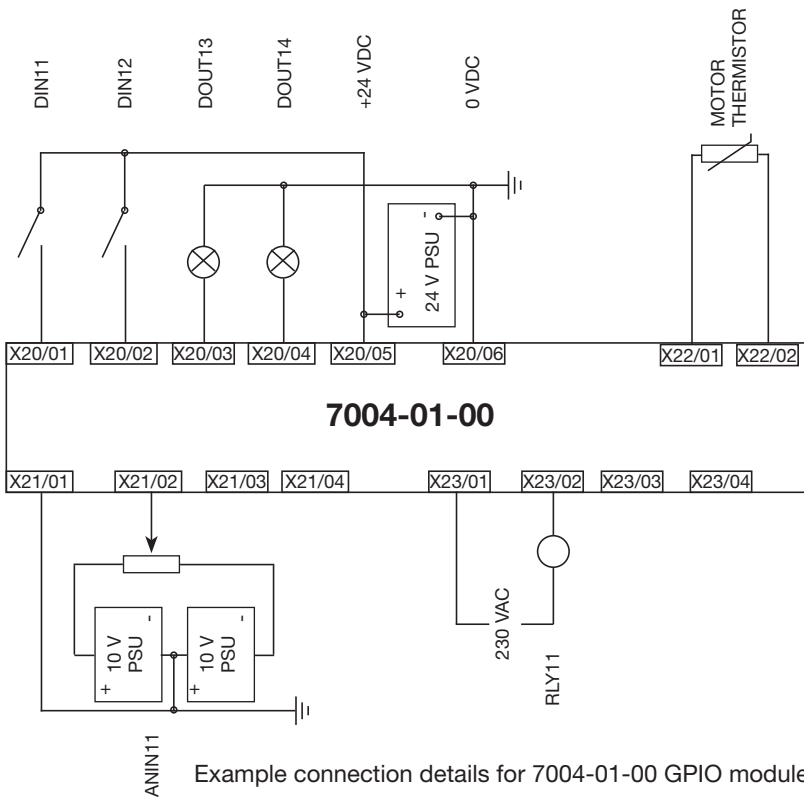

Terminal	Label
X20/01	DIN11/DOUT11
X20/02	DIN12/DOUT12
X20/03	DIN13/DOUT13
X20/04	DIN14/DOUT14
X20/05	+24 VDC
X20/06	0 VDC COMMON
X21/01	REFERENCE
X21/02	ANIN11
X21/03	REFERENCE
X21/04	ANIN12
X22/01	MOTOR THERMISTOR
X22/02	MOTOR THERMISTOR
X23/01	RLY11
X23/02	RLY11
X23/04	RLY12
X23/04	RLY12

7004-02-00 - Motor Thermistor Input Module

Motor Thermistor Inputs	1 motor thermistor input
Thermistor Compatibility	PTC, NTC, KTY
Thermistor Resistance Range	0-4.5 k Ω

Description:

The isolated motor thermistor input module provides a means of monitoring motor temperature in order to protect the motor from a potentially damaging high temperature. By default the drive will trip if the motor exceeds a user-defined temperature threshold thereby preventing motor temperature from rising further.



Input and Output Cards

7004-03-00 - Real Time Clock and Motor Thermistor Input Module

Motor Temperature Sensing	1 motor thermistor input
Thermistor Compatibility	PTC, NTC, KTY
Thermistor Resistance Range	0 - 4.5 k Ω
Time Format	Seconds
Accuracy (drive powered)	± 1 minute / month (RTC trim=0)
Accuracy (drive unpowered)	± 5 minutes / month (RTC trim=0)
Battery Backup Duration	6 Months

Description:

A real-time clock (RTC) is provided for the user to program the drive to perform functions at specified times. The RTC has battery backup, so it continues to run when the drive is unpowered. The battery recharges when the drive is powered.

An isolated motor thermistor input is also included in the 7004-03-00 module.



7004-04-00 - Pulse Encoder Feedback Module

Maximum Input Frequency	250 Hz per channel
Supply Voltage Output	5 V, 12 V, 15 V, 24 V
Input Format	Quadrature, or Clock (inputs A & /A) and Direction (input B & /B)
Motor Thermistor Details	Same as 7004-02-00

Description:

The pulse encoder feedback module provides the provision for an incremental encoder to be connected to the AC30, allowing users to take full advantage of the enhanced torque control and speed regulation functionality of the drive. In addition, the 7004-04-00 option module is equipped with a single motor thermistor input. This option can be used with all AC30 series control modules to provide full closed-loop vector induction motor control. The option can also be used to provide a speed reference into any AC30 control module.

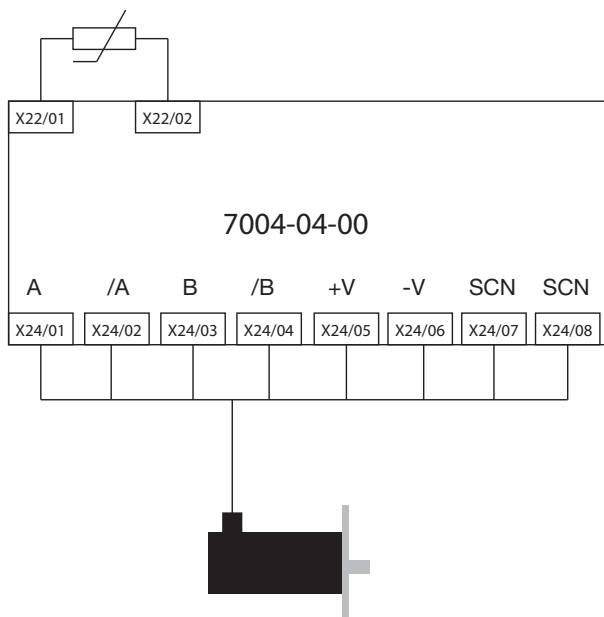

Terminal	Description
X24/01	Channel A
X24/02	Channel /A
X24/03	Channel B
X24/04	Channel /B
X24/05	Supply positive
X24/06	Supply negative
X24/07	Cable screen
X24/08	Cable screen
X22/01	Motor thermistor
X22/02	Motor thermistor

Accessories

Three Phase Reactors

Line reactors have been selected for the AC30 series to add inductance to reduce the harmonic content of the supply current.



Order Code	Motor Power Normal Duty [HP/kW]	Inductance [mH]	Current [A _{rms}]
CO470651	1.5/1.1	6.5	4
	2.0/1.5		
CO352782	3.0/2.2	5	8
CO470652	5.0/4.0	3	8
CO352783	7.5/5.5	2.5	12
CO352785	10/7.5	1.5	18
CO352786	15/11	1.2	25
	20/15		
CO352901	25/18	0.8	35
	30/22		
CO352902	40/30	0.7	45
CO352903	50/37	0.5	55
CO352904	60/45		
	CO352905	75/55	0.4
CO352906	100/75	0.3	100
CO470057	125/90	0.2	130
CO470045	150/110	0.15	160
CO470046	200/132	0.11	200
CO470047	250/160	0.09	250
CO470048	300/200	0.075	320
	350/250		
		0.06	400
		0.06	400

EMC Filters

A range of custom designed optional EMC (Electromagnetic Compatibility) filters are available for use with the Parker Drives product range. They are used to help achieve conformance with the EMC directive BS EN 61800-3:2004 - "Adjustable speed electrical power drive systems Part 3".



Order Code	Motor Power Normal Duty [HP/kW]	Frame Size
CO501894	1.5/1.1	D
	2.0/1.5	D
	3.0/2.2	D
	4.0/3.0	D
	5.0/4.0	D
	7.5/5.5	D
	10/7.5	E
	15/11	E
CO501895	20/15	F
	25/18	F
	30/22	G
Consult Factory	40/30	G
	50/37	G
Consult Factory	60/45	H
	75/55	H
	100/75	H
	125/90	J
	150/110	J
	200/132	J
	250/160	K
	300/200	K
	350/250	K

Accessories

Braking Resistors

These resistor sets are designed for stopping the system at rated power. They are rated for 10 seconds in a 100 second duty cycle. They should be mounted on a heatsink (back panel) in a protected area and covered to prevent injury from burning.



Resistor Order Code	Drive Part Number	Motor Power Normal Duty [HP/kW]	Motor Power Heavy Duty [HP/kW]	Resistance [Ω]	Power [W]	Current [A]	Type	Dimensions [in] (LxWxH)
LA471353	31V-4D0005	2.0/1.5	1.5/1.1	500	60	0.347	Metal clad	4x1x1.6
	31V-4D0006	3.0/2.0	2.2/1.5	500	60	0.347	Metal clad	4x1x1.6
LA471355	31V-4D0008	4.0/3.0	3.0/2.2	200	100	0.71	Metal clad	6.5x1x1.6
	31V-4D0010	5.0/4.0	4.0/3.0	200	100	0.71	Metal clad	6.5x1x1.6
LA471356	31V-4D0012	7.5/5.0	5.5/4.0	100	100	1.0	Metal clad	6.5x1x1.6
LA471357	31V-4E0016	10/7.5	7.5/5.5	100	200	1.4	Metal clad	6.5x1.2x2.4
LA471358	31V-4E0023	15/10	11/7.5	56	200	1.9	Metal clad	6.5x1.2x2.4
LA471359	31V-4F0032	20/15	15/11	56	500	3.0	Metal clad	13.2x1.2x2.4
LA471361	31V-4F0038	25/20	18.5/15	30	750	5.0	Cage	13.5x7x5
LA471362	31V-4G0045	30/25	22/18.5	25	756	5.5	Cage	13.5x7x5
LA471350	31V-4G0060	40/30	30/22	22.5	1134	7.1	Cage	13.5x10x5
LA471364	31V-4G0073	50/37	40/30	18	1123	7.9	Cage	13.5x10x5
LA471365	31V-4H0087	60/45	50/37	15	1135	8.7	Cage	13.5x10x5
LA471352	31V-4H0105	75/55	60/45	9	2247	15.8	Cage	13.5x10x7.5
LA471367	31V-4H0145	100/75	75/55	8	1502	13.7	Cage	13.5x13x5
LA471369	31V-4J0180	125/90	100/75	6	2258	19.4	Cage	20x18x10
	31V-4J0205	150/110	125/90	6	2258	19.4	Cage	20x18x10
LA474711	31V-4J0260	200/132	150/110	4.5	4000	30	Cage	25x18x10
	31V-4K0315	250/160	200/132	4.5	4000	30	Cage	25x18x10
	31V-4K0380	300/200	250/160	4.5	4000	30	Cage	25x18x10
LA471370	31V-4K0440	350/250	300/200	3	4563	39	Cage	25x18x10

Line Fuses

These fuses, when used with the specified drive, are recommended to provide protection under short circuit conditions.

Fuse Order Code	Drive Part Number	Fuse Type	Current (Amps)	Fuse Order Code	Drive Part Number	Fuse Type	Current (Amps)
CS470754U006	31V-4D0004	AJT6	6	CS470754U100	31V-4G0073	A50QS100	100
CS470754U010	31V-4D0005	AJT10	10	CS470408U125	31V-4H0087	A50QS125	125
	31V-4D0006			CS350263	31V-4H0105	A50QS150	150
CS470754U015	31V-4D0010	AJT15	12	CS470408U200	31V-4H0145	A50QS200	200
CS470754U020	31V-4D0012	AJT20	20	CS470408U250	31V-4J0180	A50QS250	250
CS470754U025	31V-4E0016	AJT25	25	CS350265	31V-4J0205	A50QS300	300
CS470754U030	31V-4E0023	AJT30	30	CS350266	31V-4J0260	A50QS350	350
CS470754U040	31V-4F0032	AJT40	40	CS470408U400	31V-4K0315	A50QS400	400
CS470754U050	31V-4F0038	AJT50	50	CS470408U500	31V-4K0380	A50QS500	500
CS351627	31V-4G0045	A50QS60	60	CS470408U600	31V-4K0440	A50QS600	600
CS470754U080	31V-4G0060	A50QS80	80				

AC30 Series Product Configuration

The AC30 is a modular product, allowing users to select the correct power stack, control module and options to perfectly match their application. Simply select the required parts to build a product bill of materials that meets your requirements. Minimum required parts to build a complete drive is one control module and one power stack.

Control Modules



AC30V Control Module



AC30P Control Module



AC30D Control Module

30V Codes	30P Codes	30D Codes	Description
30V-2S-0000	30P-2S-0000	30D-2S-0000	Control module with graphical keypad and standard coating
30V-1S-0000	30P-1S-0000	30D-1S-0000	Control module with blanking cover and standard coating
30V-0S-0000	30P-0S-0000	30D-0S-0000	Control module with standard coating and no graphical keypad
30V-2E-0000	30P-2E-0000	30D-2E-0000	Control module with graphical keypad and enhanced coating
30V-1E-0000	30P-1E-0000	30D-1E-0000	Control module with blanking cover and enhanced coating
30V-0E-0000	30P-0E-0000	30D-0E-0000	Control module with enhanced coating and no graphical keypad



Accessories

Graphical Keypad

Order Code	Description
7001-00-00	Graphical keypad for local or remote mounting
7001-01-00	Keypad blanking cover
LA501991U300	Keypad remote mounting kit (3 m cable and screws)



I/O Options

Order Code	Description
7004-01-00	General purpose I/O module
7004-02-00	Motor thermistor input module
7004-03-00	Real time clock and motor thermistor input module
7004-04-00	Pulse encoder feedback card

Communication Interfaces



Order Code	Description
7003-PB-00	Profibus DPV1
7003-PN-00	Profinet IO
7003-DN-00	DeviceNet
7003-CN-00	ControlNet
7003-CB-00	CANopen
7003-IP-00	Ethernet/IP
7003-IM-00	Ethernet TCP
7003-EC-00	EtherCAT
7003-BI-00	BACnet IP
7003-BN-00	BACnet MSTP
7003-RS-00	RS485/Modbus RTU

AC30 Complete Drive Product Order Code

The AC30 series may be configured to order under a single product number. This product code includes one power stack and one control module. Option modules must still be ordered separately. Please see table on page 9 for complete list of features offered by each of the AC30 variations.

	1	2	3	4	5	6	7	8	
Order example	31V	4	D	0004	B	E	2	S	0000

1 Device Family

31V	AC30V - basic standalone unit for single axis applications
31P	AC30P - Includes peer-to-peer and advanced comms
31D	AC30D - Includes dual encoder ports and encoder output

2 Voltage

4	400 V nominal (400 - 460)
----------	---------------------------

3 Frame Size and Current Rating

	HP (normal/heavy duty)	kW (normal/heavy duty)
D0004	1.5/1.0	1.1/0.75
D0005	2.0/1.5	1.5/1.1
D0006	3.0/2.0	2.2/1.5
D0008	4.0/3.0	3.0/2.2
D0010	5.0/4.0	4.0/3.0
D0012	7.5/5.0	5.5/4.0
E0016	10/7.5	7.5/5.5
E0023	15/10	11/7.5
F0032	20/15	15/11
F0038	25/20	18.5/15
G0045	30/25	22/18.5
G0060	40/30	30/22
G0073	50/40	37/30
H0087	60/50	45/37
H0105	75/60	55/45
H0145	100/75	75/55
J0180	125/100	90/75
J0205	150/125	110/90
J0260	200/150	132/110
K0300	250/200	160/132
K0380	300/250	200/160
K0440	350/300	250/200

4 Brake Switch ⁽¹⁾

B	Brake switch fitted (standard)
----------	--------------------------------

5 EMC Filter ⁽²⁾

N	No filter fitted
E	Category C3 filter fitted (standard)
F	Category C2 filter fitted - consult fact.

6 Graphical Keypad

0	No keypad fitted
1	Blanking cover fitted
2	Graphical keypad fitted

7 Environmental Coating ⁽³⁾

S	Standard 3C3 coating
E	Enhanced coating

8 Special Options

0000	No special options
-------------	--------------------

⁽¹⁾ Drives include brake switch as standard. For non-brake options please contact ssdedcs@parker.com

⁽²⁾ The choice of filter should be determined by the environment in which the drive will be installed as defined in IEC/EN61800-3
C2 = domestic & commercial, C3 = industrial

⁽³⁾ AC30 is conformally coated as standard for use in environments class 3C3 and 3C4 for Hydrogen Sulphide gas. It is also compliant to both classes 3C1 (rural) and 3C2 (urban) for all nine substances defined in table 4 in EN60271-3-3

C2 filter only offered on frames D-H. For other frames use external EMC filter

AC30 DC Supply Unit Product Order Code

The AC30 series supply units offer four quadrant (supply and regeneration) DC power for system applications.

	1	2	3	4	5	6	
Order example	380	5	R	0094	N	E	0000

1	Device Family
380	AC30 Series 4 Quadrant Supply
2	Voltage
5	400 V - 500 V nominal
3	Frame Size and Current Rating
	Output Driving Current Rating / Nominal Driving Power at 500V
R0094	94A / 60 kW
R0157	157A / 100 kW
S0251	251A / 160 kW
S0394	394A / 250 kW
S0536	536A / 340 kW

4	Brake Switch ⁽¹⁾
N	No brake switch fitted (standard)
5	EMC Filter ⁽²⁾
E	Category C3 filter fitted (standard)
6	Special Options
0000	No special options

Accessories

Harmonic Filter

Supply unit input filter required to achieve reduced harmonics.

Order Code	Description
CO3705060	60 kW Harmonic Filter
CO3705100	100 kW Harmonic Filter
CO3705160	160 kW Harmonic Filter
CO3705250	250 kW Harmonic Filter
CO3705350	350 kW Harmonic Filter

Accessories

Graphical Keypad

Order Code	Description
7001-00-00	Graphical keypad for local or remote mounting
7001-01-00	Keypad blanking cover
LA501991U300	Keypad remote mounting kit (3 m cable and screws)

I/O Options

Order Code	Description
7004-01-00	General purpose I/O module
7004-02-00	Motor thermistor input module
7004-03-00	Real time clock and motor thermistor input module
7004-04-00	Pulse encoder feedback module

Communication Interfaces

Order Code	Description
7003-PB-00	Profibus DPV1
7003-PN-00	Profinet IO
7003-DN-00	DeviceNet
7003-CN-00	ControlNet
7003-CB-00	CANopen
7003-IP-00	Ethernet IP
7003-IM-00	Ethernet TCP
7003-EC-00	EtherCAT
7003-BI-00	BACnet IP
7003-BN-00	BACnet MSTP
7003-RS-00	RS485/Modbus RTU

Parker DSE Lite Software

Description

DSE Lite is a programming, monitoring and diagnostic software platform that is compatible with the AC30 and most Parker drives, including legacy products. With the on-line help feature, users can achieve the optimum drive configuration without the need to navigate through complicated parameter menus. Advanced programming is carried out through a set of pre-engineered templates in order to create the required configuration. It is possible to monitor every parameter of the drive either as a digital value or as a function in the “chart recorder” during normal operation.



Using straightforward block programming, DSE allows the user to create, parameterize and configure user defined applications thanks to function blocks dedicated to speed control, inputs, outputs, ramps, winder functions, PID, diameter calculator, and more. Groups of function blocks can be combined into macros for more complex programs.

Parker DSE Lite can be downloaded free of charge from the Parker website.
www.parker.com/ssdusa/software

Parker Drive Quicktool (PDQ) Software

Description

PDQ is a programming, monitoring and diagnostic software platform for AC30 Series variable speed drives. Communication between the drive and PC is via the in-built Ethernet port at the top of the drive. The software will automatically detect all AC30s connected to the Ethernet network.

A number of wizards guide users through every aspect of using the software:

- Setup wizards guide the user through every stage of commissioning a new drive or reconfiguring an existing drive, from selecting a motor from the supplied database, or entering specific motor data, through to configuring application macros or control logic to suit your specific application.
- Tuning wizards allow technicians to monitor and adjust drive parameters in either a simple predefined environment or an advanced mode which allows access to every parameter in the drive.

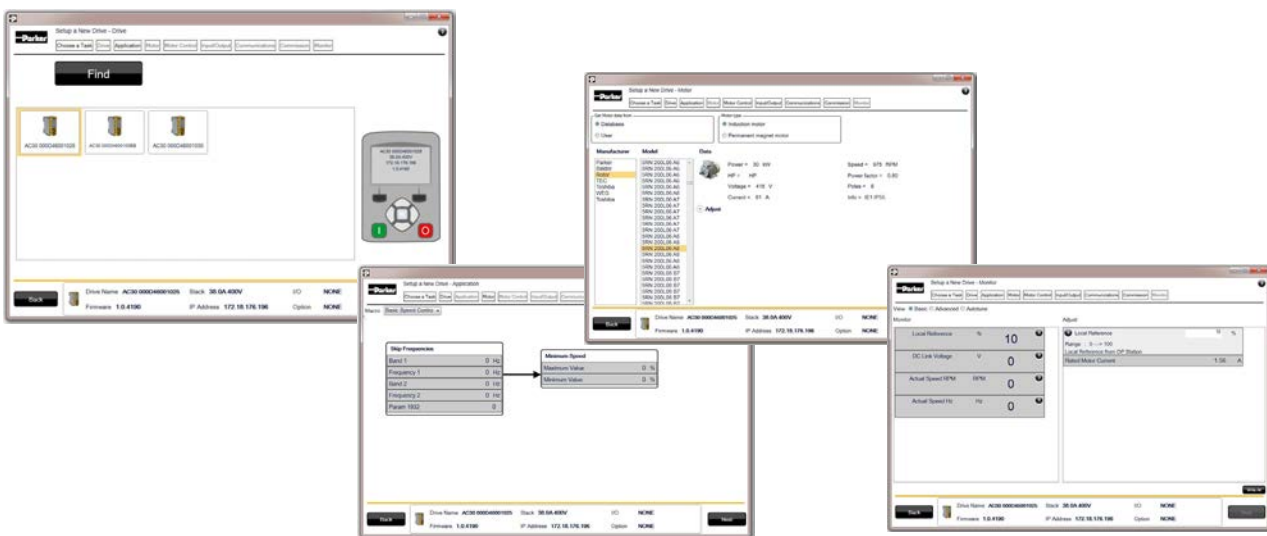

Parker Drive Quicktool is shipped with every drive and can also be downloaded free of charge from the Parker website.
www.parker.com/ssdusa/software

Related Products

Inverter and Vector Duty Induction Motors

Description

Parker can provide Inverter Duty and Vector Duty motors that let you get the most out of your drive. With your choice of a wide variety of frame styles, every rating includes specific features demanded by high performance drive applications.

Cast iron frames with totally enclosed non-ventilated construction are available for harsh environments, while compact laminated frame designs with forced ventilation can fit into the tightest spaces while providing 1000:1 constant torque speed range and excellent dynamic performance.

Not all motors are created equal. Don't settle for a re-rated constant speed motor for variable speed applications. All Parker Inverter and Vector Duty motors are provided with insulation that is suitable for use with IGBT based PWM drives, and with 200% torque overload capability. Ask for a performance-matched package every time.



The RPM AC™ series of AC motors was designed specifically for inverter duty performance, and offers high performance over a wide speed range. The compact, square cross-section, laminated steel frame includes cast iron brackets with feet for maximum ruggedness and stability. The low inertia design allows fast acceleration and high dynamic response. And to assure long and reliable motor life, Corona-Free insulation is used on all ratings.



For applications in tougher environments, we offer V*S Master™, featuring cast iron frame and end shields. Overload is no problem, with 200% capability for 60 seconds. Corona-Free insulation and an insulated CE bearing extend lifetime.

NX Series PMAC Sensorless Motors

0.2 - 7.5 kW, 0.45 - 41 Nm

Description

The sensorless version of NX Series motors has been designed to offer a cost effective brushless motor solution when used in conjunction with AC30 drives. Controlled without feedback sensor, NX Series servomotors are a compact, high performance, and extremely efficient alternative to traditional induction motors.

Features and Benefits

- Cost effective brushless solution
- Sensorless control with AC30 drives
- More compact and efficient than induction motors
- More robust design due to the lack of feedback sensor
- No need for cooling fan



Parker offers a comprehensive range of drive products that are sold, supported and serviced worldwide. They are easy to configure and commission, with simple but flexible function block-based configuration tools, “cloning” capability, intuitive keypad/display, and connectivity with all of the major industrial fieldbus networks.

Basic Drives for simple applications: AC10 Series

- Motor control for complex applications up to 250 HP
- IP66 ratings available for wet or dusty environments.



High Performance Drives for Integrators: AC690+ Series

- Motor control for complex applications up to 1500 HP
- Multiple communications and control options for flexibility.



Modular AC Systems Drives: AC890 Series

- Modular design to minimize space in multiple axis applications
- Torque, speed and position control
- Stand-alone or common bus DC modules



High Power AC Drives: AC890PX

- Modular systems drive with power output to 1800 HP.
- Removable phase and control modules for easy servicing
- Air cooled or liquid cooled variants available



Digital DC Drives

- Modernize and retrofit aging “SCR Drives” and motor/gen sets
- Feature set similar to AC690+ for ease of system integration



Hydraulic Technology

Parker Hannifin has extensive experience in the speed control of hydraulic systems. Working with a certified Parker Hydraulic Technology Center, we can provide energy efficient solutions to hydraulic power systems.



Motion Controllers, HMI, Accessories

Parker offers a comprehensive line of Programmable Automation Controllers. Similarly, we offer choices in the HMI, including Parker touchscreen displays with InteractX software.



Parker Worldwide

AE – UAE, Dubai

Tel: +971 4 8127100
parker.me@parker.com

AR – Argentina, Buenos Aires

Tel: +54 3327 44 4129

AT – Austria, Wiener Neustadt

Tel: +43 (0)2622 23501-0
parker.austria@parker.com

AT – Eastern Europe,

Wiener Neustadt
Tel: +43 (0)2622 23501 900
parker.easteurope@parker.com

AU – Australia, Castle Hill

Tel: +61 (0)2-9634 7777

AZ – Azerbaijan, Baku

Tel: +994 50 2233 458
parker.azerbaijan@parker.com

BE/LU – Belgium, Nivelles

Tel: +32 (0)67 280 900
parker.belgium@parker.com

BR – Brazil, Cachoeirinha RS

Tel: +55 51 3470 9144

BY – Belarus, Minsk

Tel: +375 17 209 9399
parker.belarus@parker.com

CA – Canada, Milton, Ontario

Tel: +1 905 693 3000

CH – Switzerland, Etoy

Tel: +41 (0)21 821 87 00
parker.switzerland@parker.com

CL – Chile, Santiago

Tel: +56 2 623 1216

CN – China, Shanghai

Tel: +86 21 2899 5000

CZ – Czech Republic, Klecany

Tel: +420 284 083 111
parker.czechrepublic@parker.com

DE – Germany, Kaarst

Tel: +49 (0)2131 4016 0
parker.germany@parker.com

DK – Denmark, Ballerup

Tel: +45 43 56 04 00
parker.denmark@parker.com

ES – Spain, Madrid

Tel: +34 902 330 001
parker.spain@parker.com

FI – Finland, Vantaa

Tel: +358 (0)20 753 2500
parker.finland@parker.com

FR – France, Contamine s/Arve

Tel: +33 (0)4 50 25 80 25
parker.france@parker.com

GR – Greece, Athens

Tel: +30 210 933 6450
parker.greece@parker.com

HK – Hong Kong

Tel: +852 2428 8008

HU – Hungary, Budapest

Tel: +36 1 220 4155
parker.hungary@parker.com

IE – Ireland, Dublin

Tel: +353 (0)1 466 6370
parker.ireland@parker.com

IN – India, Mumbai

Tel: +91 22 6513 7081-85

IT – Italy, Corsico (MI)

Tel: +39 02 45 19 21
parker.italy@parker.com

JP – Japan, Tokyo

Tel: +81 (0)3 6408 3901

KR – South Korea, Seoul

Tel: +82 2 559 0400

KZ – Kazakhstan, Almaty

Tel: +7 7272 505 800
parker.easteurope@parker.com

LV – Latvia, Riga

Tel: +371 6 745 2601
parker.latvia@parker.com

MX – Mexico, Apodaca

Tel: +52 81 8156 6000

MY – Malaysia, Shah Alam

Tel: +60 3 7849 0800

NL – The Netherlands,

Oldenzaal
Tel: +31 (0)541 585 000
parker.nl@parker.com

NO – Norway, Ski

Tel: +47 64 91 10 00
parker.norway@parker.com

NZ – New Zealand, Mt Wellington

Tel: +64 9 574 1744

PL – Poland, Warsaw

Tel: +48 (0)22 573 24 00
parker.poland@parker.com

PT – Portugal, Leca da Palmeira

Tel: +351 22 999 7360
parker.portugal@parker.com

RO – Romania, Bucharest

Tel: +40 21 252 1382
parker.romania@parker.com

RU – Russia, Moscow

Tel: +7 495 645-2156
parker.russia@parker.com

SE – Sweden, Spånga

Tel: +46 (0)8 59 79 50 00
parker.sweden@parker.com

SG – Singapore

Tel: +65 6887 6300

SK – Slovakia, Banská Bystrica

Tel: +421 484 162 252
parker.slovakia@parker.com

SL – Slovenia, Novo Mesto

Tel: +386 7 337 6650
parker.slovenia@parker.com

TH – Thailand, Bangkok

Tel: +662 717 8140

TR – Turkey, Istanbul

Tel: +90 216 4997081
parker.turkey@parker.com

TW – Taiwan, Taipei

Tel: +886 2 2298 8987

UA – Ukraine, Kiev

Tel: +380 44 494 2731
parker.ukraine@parker.com

UK – United Kingdom,

Warwick
Tel: +44 (0)1926 317 878
parker.uk@parker.com

US – USA, Cleveland

Tel: +1 216 896 3000

VE – Venezuela, Caracas

Tel: +58 212 238 5422

ZA – South Africa,

Kempton Park
Tel: +27 (0)11 961 0700
parker.southafrica@parker.com

