

Rapid RAPTOR^{series}

Open-Hearted **Power**



RAPTOR 800
RAPTOR 1350

New generation **SHREDDERS**

Rapid Open-Hearted RAPTOR shredders

The new modular shredders come in two widths, 800 and 1350 mm. With the modular series 36 base configurations, the Raptors recycle all kinds of plastics. Thin film, heavy lumps or light weight bulky containers, all is converted into finest chips for further treatment.

QuadCUT knife design

Not only the handling is outstanding. The new patented Rapid QuadCUT knife design offers four true cutting edges per knife in a solid piece which makes the knives the toughest you can get. Furthermore, the knives are clamped in a rock solid design, including a shock absorber to protect the rotor from being destroyed in a sudden impact from any metal etc. that accidentally entered the cutter house

Integration with granulator

The Raptor shredders are designed to interact with the also new Rapid 300-LBB granulator, a serie of low-built and compact granulators, forming the Raptor DUO. The output from the Raptor feeds directly into the granulator.





Open-Hearted **RAPTOR**

The new Raptor Series of shredders is a showcase of how we take advantage of 75 years of expertise from the plastics industry and granulators. The new shredder are innovative, uses open-hearted technology and has a unique patented cutting action – in short, it offers the best shredding solution for plastics in the market.

Rapid introduced the Open-Hearted technology to granulators, we've now used the way of thinking to shredders. In less than a minute, the shredder is opened up, offering full access to the machine interior. Cleaning with full visibility, changing knives without climbing the machine and many more features make the Raptor Shredders unique.

Rapid Raptor shredders

“Open-Hearted POWER”

- Recycles all plastic**
 Heavy lumps, thin film or light weight 1.2 m³ IBC containers, all is possible in the Rapid Raptor series.
- Open-Hearted technology**
 Less than a minute! That's all it takes to open up the complete machine for cleaning or maintenance. A single tool is all you need in true Rappid manner. Access given to the complete interior, providing clear view of cutter house and rotor.
- Patented unique knife design, QuadCUT**
 What is weakest point in a shredder knife? The commonly used centre bolt hole! That's why Rapid's new QuadCUT knives are completely solid, yet, the fastening is rock solid thanks to a unique clamping system that makes the knife self positioning. In addition, it has four cutting edges, exposed one at the time to make them last long.
- Protected rotor**
 The rotor is the heart in every recycling machine and it has to be protected. If it breaks, your production stops. Rapid's QuadCUT design impact absorber behind every knife that will take the punch if something have come into the cutting chamber that suddenly blocks the rotor. In many cases, only the knife and pad will be destroyed, but the rotor will run again after a quick knife change.
- Customizeable tilt back hopper**
 Hoppers are easy to adopt to different types of production. Just swapping the upper part (containing no cables or other things interfering) makes it easy to make fast changes in infeed method.

QuadCUT

Rapid's new patented cutting system.

A complete new knife design containing a rock solid clamping design with four long-lasting knife edges. Each knife has a built-in shock absorber which helps to protect the rotor from sudden impacts.



Heavy duty transmission

The heavy duty design of the gear box makes it reliable, energy efficient and at the same time quiet. It's belt driven for efficient operation.



Screens if needed

The Raptor shredders run fine without screens, but screens with different hole sizes are available. As in Rapid's large granulators, the screens are split in two to ease handling.

The turnable screens are unbolted and unwelded making it very easy to remove when cleaning and servicing.



PLC programming

The Raptors come with programs for standard applications. More flexibility is achieved by optional PLC programming, also offering operation and logging from a pad or PC.



Mineral Composite Technology Base, MCT

The Raptor-Series' base can be made of a special mineral composite material to give extra stability, reducing vibrations even in the toughest applications.

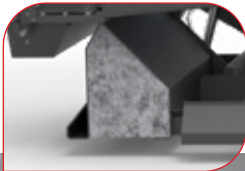

Extensive safety systems
 With multiple sensors, the Raptors are safe to operate. Access is not given until the rotor has stopped.

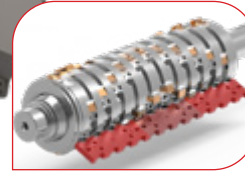

Single unit fixed knife system
 The unique fixed knives solution is based on a single article which fit in all positions and all widths. The turnable knives have 4 true cutting edges. Knife position is pre-set and knife clearance can easily be fine tuned.



Split cutterhouse
 If a worst case scenario should happen and the rotor needs to be removed for repair it is easily done. The split cutterhouse sides make the rotor easy to lift out of the machine without removing the hopper.



Pusher Systems

Pneumatic or hydraulic pusher

Pusher technology is chosen based on what to shred, at which capacity and other criteria. Both our pneumatic and hydraulic pusher technologies include shock absorber, reducing stress and protecting the machine.

Pneumatic FlexiPUSH

In most applications, recycling lumps, volume goods etc. the FlexiPUSH works effectively. The built-in shock absorber protects the machine from stress and vibration.



TopPUSH

In some cases, mostly when recycling bulky and very light weight materials, a Top Pusher helps keeping material down to the rotor to maintain a high output.

Hydraulic PowerPUSH

In applications, such as film, sheets etc., when maximized capacity is required, the PowerPUSH provides the pressure needed.

The hydraulic pusher has multiple shock absorbing valves and built-in safety to protect the shredder.

The bottom in the chamber is ribbed to avoid jamming parts and pieces and the bottom of the chamber is angled to drain any residual liquids from shredded materials such as baled bottles etc.



Rotors and knife systems



Single/Double knife rows

To increase throughput the rotor can be configured with double knife rows giving twice as many cuts per revolution which significantly increase the capacity.



Rotor diameters

The Raptor 800/1350 comes with a 280 mm diameter rotor. In applications where high capacities are of major importance a Raptor with larger rotor diameter offer this capability.



QuadCUT configuration

The unique QuadCUT is the best solution for general plastic with no or limited contamination. It offers clean cut with high output for most materials.



Claw rotor

For general plastic waste and special applications. The claw knives are fixed by a bolted knife holder, easy to change if necessary. The knives are reversible with 4 cutting edges and offer clean, efficient cutting.

Rotors are single or double knife rows.



Power wedge rotor configuration

The Power wedge knife rotor is primarily designed for recycling of thin film and raffia materials.

Specifications

	Raptor 800	Raptor 1350
--	------------	-------------

Rotor diam. (mm)	280	
	Single row knives	
Rotating knives, single knife row	23	39
Fixed knives	3	5
Cutterhouse, PowerPUSH, mm	800x780	1350x780
FlexiPUSH, mm	800x1010	1350x1010
Hopper inlet, PowerPUSH, WxH	800x1490	1350x1490
FlexiPUSH	800x1350	1350x1350
Motor alternatives, kW	11-45	
Throughput capacity (up to, kg/h)	1000	1500
Weight (kg)	4200	5200

Standard features

- Constant Cutting Circle, CCC
- Open-Hearted cutting chamber design
- Pre-adjustable knives, fixed and rotating
- Heavy duty transmission
- Easy removable flaps
- Solid stand with machine shoes
- Electrical jack hopper opening
- Rotor easily rotating using the door opening tool

Options

- Double knife rows on rotor
- Advanced PLC programming
- Capability to run/survail from PC/tablet/pad
- Top pusher for bulky light weight materials
- Belt conveyor for infeed
- Screens, for further controled output, diam. (mm) 16, 25, 38, 50, 62, 75

All data given is depending on configuration, material etc.

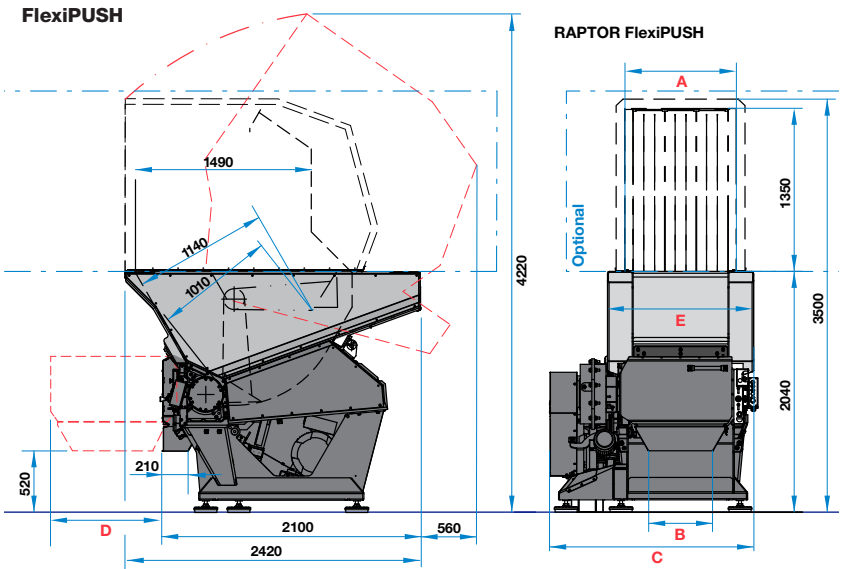

Model	A	B	C	D	E
Raptor 800 FlexiPUSH	800	520	1730	600	1240
Raptor 1350 FlexiPUSH	1350	1070	2280	1150	1790
Raptor 800 PowerPUSH	800	500	1710	620	1070
Raptor 1350 PowerPUSH	1350	1050	2260	1170	1620

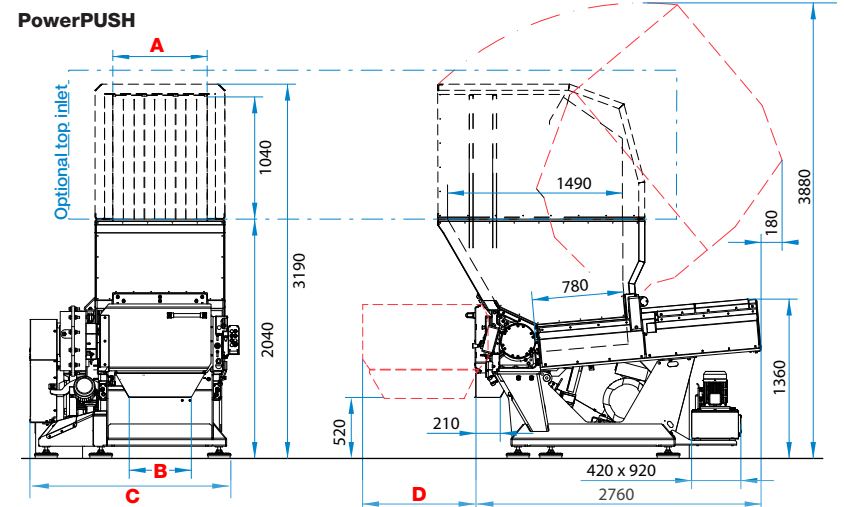

All dimensions in mm.

Get **MORE** performance from your Rapid equipment!

Preventive maintenance is the key to high-quality regrind, keeping down life-cycle costs and, in the worst cases, avoiding costly breakdowns that can stop production. This is why you should service and maintain your granulators regularly, with the frequency determined by your specific application demands.

With installation and service from your local Rapid Service Team, you can rest assured that your granulator will deliver high availability, efficient performance and a long life, year after year.

Our spares and service team is just a phone call away to provide you all the help you need with service, maintenance and replacement parts. Our promise is simple: your request will be handled promptly, typically within a few hours.



Rapid 5-year extended warranty

With a preventive maintenance program in place and the use of original Rapid spare parts you will experience the same superior performance from your granulator as you did day one.

Our commitment is underscored by the 5-year extended warranty that you receive for free with all new Rapid granulators. All you need to do is register your granulator (see below). The only exception to the warranty is if you use abrasive materials. This will, according to normal

branch practice, turn the rotor and cutterhouse into wear parts, and thus exclude it from the extended warranty.

The warranty is valid for five years if you can show a documented maintenance history (as stated in the Rapid user's manual) and, of course, the use of Rapid original spare parts.

Rapid Service Center

Get the most out of your Rapid granulator, – register it today!

In the Rapid Service Center you get on-line access to your granulators documentation, including:

- manual, forget about lost manuals, it's always available
- electrical drawings of your individual machine
- program for all service activities; weekly, monthly etc.
- the service log supports the extended Rapid 5-Year warranty
- direct link to the Rapid Spare Parts Team to order the correct parts, for your individual machine, when you need.

Register your granulator at <https://service.rapidgranulator.com>



1 Register your Rapid granulator



2 We send you a password by mail



3 Login to the Rapid Service Center



4 And a world of valuable service information

Rapid Granulator AB, Sweden

P.O. Box 9, SE-333 02 Bredaryd
Delivery address:
Industrivägen 4, SE-333 72 Bredaryd
Phone: +46 370 86500
Email: sales@rapidgranulator.se

Rapid worldwide:

USA	info@rapidgranulator.com
Germany	info@rapidgranulator.de
France	info@rapidgranulator.fr
Italy	info@rapidgranulator.it
China	info@rapidgranulator.cn
Asia/Pacific	info@rapidgranulator.asia

