

# Angel Hair Trap

Angel Hair Traps collect "Angel Hair", "Streamers" or "Snake Skins" common in the conveying of plastic materials at the base of a silo or storage bin in gravity applications.

## Standard Features



- Aluminum construction
- Low profile design is only 8.5" high
- Easy clean/removable screens available in Stainless Steel or Aluminum 3/4" expanded metal size (1/2" expanded metal optional)
- Standard unit mounts directly to 12" square bolt hole pattern Lorenz Maintenance Gates and Distribution (Probe) Boxes
- Optional 6" height available
- Custom sizes available

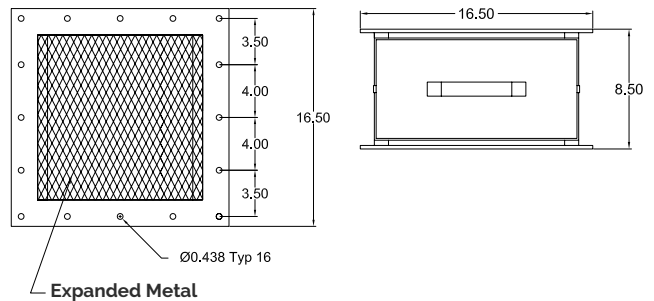

# Inline Angel Hair Trap

Designed to mount in the material stream to collect "angel hair", "streamers" or "snake skins" while allowing the pellets to pass through.

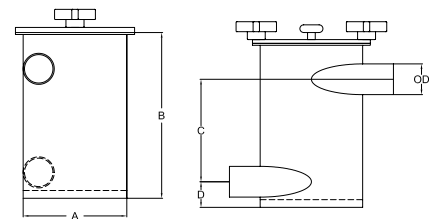

## Standard Features



- Eliminate downtime caused by Angel Hair and Streamers
- The clear viewing cover for level indication can be quickly removed for clean out
- For use in vacuum lines and pressure conveying systems
- Three standard body sizes are 8"-10" and 18" with line sizes from 1.5" OD up to 6" OD
- Body constructed of 12 gauge 304 Stainless Steel
- Connects to line with compression couplings
- Black knobs standard

OD	A	B	C	D
1.5"	8.00	10.75	6.50	2.00
2"	8.00	10.75	6.50	2.00
2.5"	10.00	16.00	10.56	2.50
3"	10.00	16.00	10.00	2.50
3.5"	10.00	16.00	9.88	2.88
4"	10.00	16.00	9.88	3.13
4.5"	10.00	16.00	9.88	3.13
5"	18.00	23.50	15.75	3.50
5.563	18.00	23.50	14.50	4.00
6"	18.00	23.50	14.38	4.13
6.625"	18.00	23.50	14.44	4.31